

## 6. INTERSECTIONS

An intersection is a location on the highway network where two or more roads or streets meet or cross. They may be classified by:

- Number of roads that meet (approach arms),
- Level (grade-separated or at-grade),
- Form of traffic control (uncontrolled, signalized, or unsignalized), or
- Layout ('T', 'Y', roundabout, raised).

Grade-separated intersections are sometimes referred to as interchanges.

It is often difficult to determine the best intersection type for any particular location, taking into account all relevant factors and several options that may be possible. The selection of an intersection involves considerations of safety and operational performance, including capacity, compatibility with adjacent intersection treatments, topography at the site, and other factors (see further reading: Guide to Traffic Management Part 6).

Generally, it can be expected that different driving standards and driving behavior will exist in low- and middle-income countries (LMICs) and this may result in some intersection types being unsuitable for use in such countries.

However, from a safety perspective some intersection types are far safer than others. This section provides some general principles related to intersection safety to aid in the selection of intersection types from a safety perspective. More detailed information on each intersection type and other intersection considerations are provided in the following sections.

### Safety implications

- The safety needs of all road users, including pedestrians, cyclists, motorcyclists, and people with mobility difficulties, must be considered, as their needs may be a significant factor in the choice of treatment and the type of traffic control adopted.
- Vehicle speeds through an intersection must be managed safely. Low relative impact speeds provide a safer environment for conflicting maneuvers. When collisions do occur at lower speeds, the severity outcome tends to be lower. Speeds above 50 km/h for motorized vehicles, and above 30 km/h for nonmotorized road users lead to increasingly severe crash outcomes (see section 3.1 on Design speed). Lower speeds enable drivers to break and stop more quickly when there are hazards; to make easier judgements regarding speeds of other vehicles and therefore decisions about appropriate gaps in traffic; and to accept smaller gaps thus reducing delays and increasing capacity.
- A change in gradient on approaches to the intersection from more than 3 percent to less than 3 percent appears to be associated with a (marginally significant) reduction in the number of injury crashes of 17 percent, but with an increase in the number of material damage-only crashes.<sup>132</sup>

### Good design practice/ treatments/solutions

- The basic principles of good intersection design are that they should allow transition from one route to another or through movement on the main route with minimum delay and maximum safety. To do this, the layout and operation of the intersection

132 Conference of European Directors of Roads. 2008. Best Practice for Cost-Effective Road Safety Infrastructure Investments.

should be obvious and unambiguous, with good visibility between conflicting movements. These objectives need to be achieved at reasonable cost, so the provision of unnecessarily high standards as well as inadequate ones needs to be avoided. Different intersection types will be appropriate under different circumstances depending on traffic flows, speeds, and site limitations.

- Intersections should be as simple as practicable and designed to guide users safely through conflict points.
- Intersections introduce an elevated level of risk due to the number of conflict points. One strategy for reducing risk is to remove unnecessary intersections, although this requires the existence of alternative and safe options for road users.
- The various types of intersection layout can provide a hierarchy of alternative layouts catering for increasing levels of traffic flow:
  - Junctions without any designated priority—uncontrolled intersections,
  - Simple priority intersection—Stop or Yield control,
  - Priority intersections with channelization,
  - Roundabouts or signal-controlled intersections, and
  - Grade separated intersections.
- Road network planning must be well considered to avoid creating multi-arm and skewed intersections. Inappropriate approach angles will obscure a driver's sight triangle in the intersection area (figure 6.1). Furthermore, impact angles must be as small as possible (i.e., as close to parallel as possible).
- The potential for severe injury within an intersection can also be minimized through reductions in speed, reduction in the number of conflict points, separation of road users, and/or reductions in the angle of vehicle impact.
- Large intersections with little channelization or deflection can create large open unregulated spaces with multiple conflict points and high vehicle speeds. While solutions would be site specific,

**Figure 6.1:** Uncontrolled Y-intersection in India.



Source: IIT, 2019.

the general principle of reducing speed and managing conflict points should be applied to all intersection designs.

- Conflict points can be reduced through geometric design, including channelization and provision of roundabouts, the addition of deceleration lanes, realignment of the intersection, turn bans, and a reduction in traffic lanes. In general, the number of conflict points at four-leg intersections is much greater than for T-intersections. However, the number of lanes also greatly affects the number of conflict points. Roundabouts result in the fewest conflict points for a four-arm intersection (Figure 6.2).
- Separation of traffic at intersections is another effective means to improve safety, and can also produce benefits in traffic capacity. Grade separation (underpasses and overpasses) are the most substantial form of separation. These substantially reduce the change of conflict between vehicles, especially when well designed.
- Other strategies to address intersection risk include the application of traffic control devices such as signs, markings, and traffic signals. These have benefits in reducing crash risk but do not always reduce the severity of crashes. It is often beneficial from a safety perspective to combine these devices with other measures (such as reductions in speed) to achieve significant safety benefits.
- Cost and necessary activities for maintenance at an intersection should be considered.

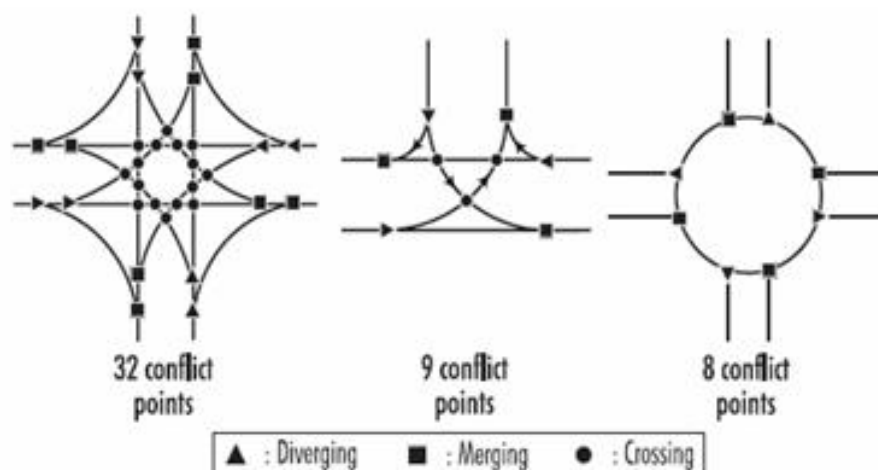
**Figure 6.2:** Conflict points of different intersection types at single-lane intersections.

Source: © European Union, 2021.

**Table 6.1:** Advantages and disadvantages of different forms of intersections

Intersection type	Traffic characteristics	Primary safety characteristics	Supporting safety measures
<b>Priority</b>	Low flows. Can have high delay to minor road traffic. No delay to major road. Major road needs stopping sight Distance.	Crossing conflicts retained and speed control issues.	Channelization Slip lanes Turn lanes Banned movements Skid resistance improvement Raised platform Advance signing
<b>Roundabout</b>	Low/medium flows. Good for turners having to both cross and merge with traffic streams. Minimal delays at lower flows (i.e., offpeak). Not good for safety of cyclists and other slow vehicles when lacking adequate provision (e.g., segregation).	Although land-hungry, single-lane versions are the closest to safe system compliance for at-grade intersection. Removes all motorized crossing conflicts and reduces them to low angle or merge/diverge. Relatively low speed environment for all, although there are challenges for nonmotorized users unless off-road facilities are provided in moderate to high-speed environments.	Flared approach Skid resistance improvement Advance signing Raised platforms Off-road facilities for cyclists Well defined crossing points for pedestrians and cyclists on each arm
<b>Traffic signals</b>	Low/medium flows. Can accommodate heavy offside turning flows by using filter signal and channelization. Require less space than roundabout. Relatively high delays at off-peak times. Maintenance and power supply can be issues in LMICs.	Separates all conflicts by time control. Requires enforcement or good compliance from all road users. Key risks to crossing traffic or vulnerable users with noncompliance.	Channelization Slip lanes Turn lanes Banned movements Speed/red light cameras Skid resistance improvement Vehicle activated signs Advance signing
<b>Grade separation</b>	High flows. Minimal delays. Requires large area. Expensive.	Removes all crossing conflicts and reduces them to merge/diverge.	Street lighting Advance signing Speed reduction/limits

## Further Reading

- Austroads. 2019. Guide to Traffic Management Part 6.
- Austroads. 2016. Safe System Assessment Framework (Research Report AP-R509-16).

## 6.1. Uncontrolled and Unsignalized (yield) Intersections

### General description

An uncontrolled intersection is an intersection controlled by only general road rules (i.e., traffic laws), with no traffic control devices such as signs, road markings additional lanes, or channelization in place. They are the simplest form of intersection provided on the road network. For example, in the US, “when two vehicles approach or enter an intersection from different highways at approximately the same time, the driver of the vehicle on the left shall yield the right-of-way to the vehicle on the right.” Uncontrolled intersections are usually limited to very low-volume roads in rural or residential areas.<sup>133</sup>

If traffic control devices are in place, then the intersection can be called an unsignalized or priority intersection. Unsignalized intersections can also be subdivided into those where the minor approach is required to yield to traffic on the main road and those where circulatory movement controls the entry of approaching traffic. This section only considers those intersections where no circulatory control is provided.

All control of potential conflicts at yield intersections, including those achieved by regulatory signs or road markings, are supported by relevant road rules. At uncontrolled intersections, only general road rules, which differ by country/region, control traffic.

However, yield intersections still often account for a high proportion of network delays, conflicts between vehicles, and conflicts between vehicles and other road users (e.g., pedestrians).

Yield intersections are suitable for situations where there are no (or are not likely be) operational problems, such as excessive delays/queues or safety problems (i.e., low traffic volume and low-speed roads, etc.).

### Safety implications

- Straight four-arm intersections often have a poor safety record because of minor road traffic failing to stop for main road traffic, either because of driver indiscipline or because the driver is not aware that there is a major road ahead.
- The major crash types at both uncontrolled and yield intersections are where vehicles fail to stop, implying inadequate visibility or awareness of the intersection.
- Crashes with emerging vehicles suggest inadequate sight lines along either the major road or minor road.
- In most of unsignalized intersections, the minor roads lack adequate sight distance, mainly due to encroachments.
- Wrong turns and chaotic traffic movements are commonly observed at these locations. Such untreated minor intersection and access roads may lead to unsafe movement of pedestrians and vehicles whenever present.
- Where intersections are uncontrolled, the lack of awareness by main road drivers for turning vehicles can result in rear-end collisions.
- If the yield line is in the dip at the edge of the major road camber, it can be invisible from a distance on the minor road.
- Speeds of approaching vehicles are also a major cause of collisions.

133 Uniform Vehicle Code at <https://iamtraffic.org/wp-content/uploads/2013/01/UVC2000.pdf>.

- For all types of uncontrolled or yield intersections, the problem of delay exists for minor road traffic. If the delays are excessive, emerging drivers may take undue risks in order to enter or cross the main stream.
- Multiple lane approaches place greater demands on the emerging driver and tend to be more hazardous locations.
- Slow-moving or stationary vehicles turning into a side road across a main road stream of traffic are often the cause of serious crashes, particularly at night.
- Problems can also be caused in urban areas by inadequate curbs that give an unclear layout and make little or no provision for pedestrians.

### Good design practice/ treatments/solutions

- In cases where there are no control devices (i.e., traffic signals and roundabouts), designating or clarifying priority rules (e.g., stop or yield signs/markings) must be provided to give clear indication of expectation to drivers (figure 6.3). This will also aid separation of conflicting movements in addition to the general intersection rules. These

**Figure 6.3:** Yield signs being used as intersection control.



Source: National Cooperative Highway Research Program. 2015. Unsignalized Intersection Improvement Guide.

devices prevent or discourage inappropriate traffic movement at the intersection.

- Traffic islands (e.g., triangular left-turn islands) and medians would help to provide delineation and direct traffic into the appropriate path through intersections.
- Although controlling traffic by police officers (or authorized persons) is often used in exceptional circumstances (e.g., peak traffic hours, road work, incidents), this might result in extra delays at the intersection.
- In case any safety treatments cannot be implemented at an uncontrolled intersection, redirecting traffic to a higher quality intersection should be considered.
- Improving intersection conspicuity and driver's sight distance at intersections must be prioritized to increase awareness and readability.
- All obstacles within intersection areas must be removed (figure 6.4). And all unnecessary conflict points must be eliminated. For example, placing a waiting space at the center of an intersection is dangerous because passengers have to enter the intersection to reach the space. Furthermore, the waiting space will be an obstacle for other road user's sights (figure 6.5).

**Figure 6.4:** Sight triangle obstacles from minor road at T-intersection.



Source: IIT, 2019.



**Figure 6.5:** Obstacle (bus stop waiting space) at center of intersection in India.



Source: IIT, 2019.

**Figure 6.6:** Stop signs with traffic calming measures at unsignalized intersection.



Source: PIARC. 2003. *Road Safety Manual*, First edition.

**Figure 6.7:** Left turn restriction by signs and median at unsignalized T-intersection.



Source: Palo Alto online. Residents frustrated by repeated traffic violations in north Palo Alto, July 5, 2017. <https://www.paloaltoonline.com/news/2017/07/04/residents-frustrated-by-repeated-traffic-violations-in-north-palo-alto>.

Below is a summary of treatments for uncontrolled/unsignalized intersections:

#### Approach and minor road treatment

- Advanced warning signs and road markings would help to indicate the existence of an intersection to drivers.
- Placing stop signs on the minor road approach to an intersection can be effective where the sight distance from the minor leg of the intersection is insufficient and it would be unsafe to proceed without stopping. But reassignment of a priority might not perform safely if placed contrary to driver expectation and it does not work as a stand-alone treatment.
- A decision as to whether a stop sign rather than a yield sign is required is based on sight distance available for drivers on the minor road approach, i.e., whether the sight distance from the minor leg of the intersection is inadequate and it would be unsafe to proceed without stopping. It has been found that the use of stop signs in locations with adequate sight distance does not provide additional safety benefits and can lead to a loss of credibility, and their effectiveness will be compromised (see section 5.13 on signs).
- Speed management, also known as “traffic calming” features (e.g., speed humps, raised intersections, etc.) are used in conjunction with stop/yield signs on approaches of intersections to help control speed (see section 3.2 on Speed compliance and traffic calming; section 6.4 on Raised intersections; figure 6.6).
- Channelization, adequate sight distance, or supplemental visibility enhancement, including lighting, should be made available at all the minor junctions.
- Provide flexible poles on both major and minor roads to separate traffic from the opposite direction. This can reduce certain types of crashes.

#### Movement prohibition measures

- Prohibition of selected movements (e.g., left in/left out, no left or right turn, full-time or part-time, etc.) can reduce certain types of crashes related to

**Figure 6.8:** No left turn sign with stop marking at unsignalized intersection in Dominica.



Source: DAVIBES. 2016. New signs erected to ease traffic congestion, March 22. <https://www.dominicavibes.dm/news-196869/>.

limited sight distance and pedestrians that involve left or right turning vehicles. This strategy can also reduce the frequency and severity of crashes.

- The prohibitions can be implemented by channelization, markings, and/or signs (figures 6.7 and 6.8). Signs and/or markings alone will require other physical interventions.
- The prohibitions may be appropriate where a turning movement is considered to be high risk and other strategies are impractical or not possible to implement. This strategy may be difficult to justify at a major intersection unless the left-turn volumes are very low. It is generally preferred to more safely accommodate the turning movement at the point where the driver desires to turn than to displace the turn activity to an alternative location.
- An auxiliary lane provides separation for the maneuvering of a vehicle and is typically used in rural areas where high-speed, low-volume traffic occurs and the volume and slow maneuvering of turning traffic is sufficient to create a conflict with following traffic.
- A left/right turning lane allows traffic to decelerate and turn without affecting through traffic (figure

**Figure 6.9:** Segregated diverge nearside unsignalized intersection.



Source: AfDB, 2014.

6.9). A right-turn auxiliary lane in left driving (left-turn auxiliary lane in right driving) without channelization might not be effective (see section 6.5 on Turning lane and Channelization).

The following are the summary of treatments for Y-(skewed) intersection.

- The speed of approaching vehicles at the intersection is affected by approach angles. Approach angles also affect the crossing distance (footprint) of vehicles at the intersection. Furthermore, appropriate approach angles may improve driver's sight triangle in the intersection area. Approach angles must be determined to achieve the following principles:<sup>134</sup>
  1. Limit turning speed around obtuse angle. Acute angled intersections reduce visibility for motorists, while obtuse intersections allow for high-speed turns. A right-angle treatment can work as speed enforcement and can improve a driver's sight triangle (figure 6.11).
  2. Shorten the crossing distance (footprint) of vehicles. Compact intersections reduce pedestrian exposure, slow traffic near conflict points, and increase visibility for all users. Both acute- and obtuse-angled intersections create unnecessarily long pedestrian crossings.

134 National Association of City Transportation Officials (NACTO). 2019. Urban Street Design Guide. Accessed at <https://nacto.org/publication/urban-street-design-guide>.

**Figure 6.10:** Island separating traffic at center of minor road.

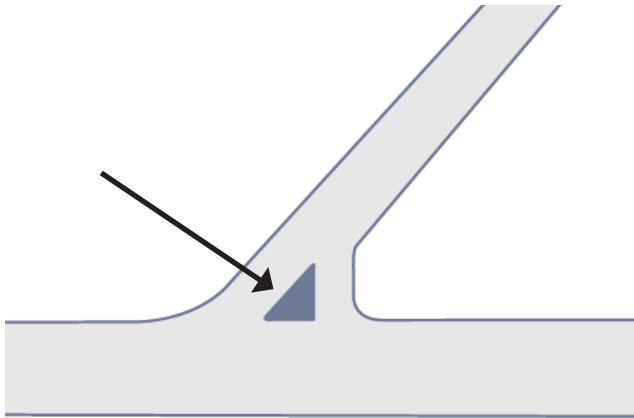

Source: NACTO

**Figure 6.11:** Curb changing angle of entering intersection from minor road

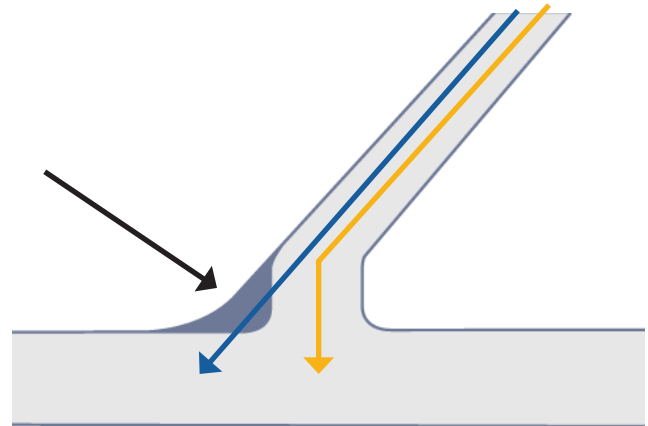

Source: NACTO.

3. Separate vehicle flows to reduce conflicts (figure 6.10).

- An angle of less than 90 degrees gives the fewest injury crashes and the opposite appears to be the case for material damage-only crashes. Redesigning an intersection of an angle less than 90° to an angle of 90° may increase injury crashes by 80 percent. On the contrary, redesigning a junction of an angle of 90° to an angle of more than 90° appears to bring a reduction of injury crashes by 50 percent.<sup>135</sup>
- Realignment of an intersection may impact sight distance and/or the impact angle for vehicles involved in collisions at the intersection. Realignment of an intersection is often too costly. It is much better to design the intersection well before it is built than to rebuild it. The reconstruction of

an intersection should be implemented when adequate sight distance and countermeasures are not available.

## Further Reading

- FHWA. 2009. Manual on Uniform Traffic Control Devices (MUTCD). Must read chapter 2b, Regulatory signs, barricades, and gates.
- Austroads Guide to Traffic Management Part 10: Traffic Control and Communication Devices (Austroads 2019e).
- Institute of Transportation Engineers (ITE). 2015. Unsignalized Intersection Improvement Guide. <https://toolkits.ite.org/uiig/>.

135 Conference of European Directors of Roads. 2008. Best Practice for Cost-Effective Road Safety Infrastructure Investments.



## Case Studies/ Examples

**Figure 6.12:** Minor road treatments—traffic calming and warning signs in India from minor road perspective.



Source: IIT, 2019.

**Figure 6.13:** Minor road treatments—traffic calming and warning signs in India from major road perspective.



Source: IIT, 2019.

**Figure 6.14:** Installing movement prohibition measures and pedestrian protection measures—Colombia.



Source: iRAP.

**Box 6.1:** Staggered Intersections

- Staggering intersections (converting to two mini-intersections) results in a reduction of the number of conflict points. This treatment can be applied at over five-arm intersections and four-arm intersections, which have obscure sight distances or have crash records (figures 6.15 and 6.16). Staggering needs to be far enough apart to operate as two, or close enough to operate as one.
- Staggered intersections may result in a 33 percent reduction of injury crashes when the traffic on the minor road is normal or heavy. The effect of staggering intersections strongly depends on the proportion of original traffic on the minor road.
- An Australian study indicates staggered T-intersections should have the following features:
  - i. Low major road traffic volumes (< 2000 vpd),
  - ii. No significant curvature of the minor road approaches,
  - iii. Left-right stagger type (driving on the left of the road), stagger distance  $\geq 15$  m,
  - iv. Warning signs on the major road, and
  - v. Not implemented at operation at or near capacity within its design life.

**Figure 6.15:** Convert four-leg intersections to two T-intersections (right-left staggered intersections). Source: NACTO.

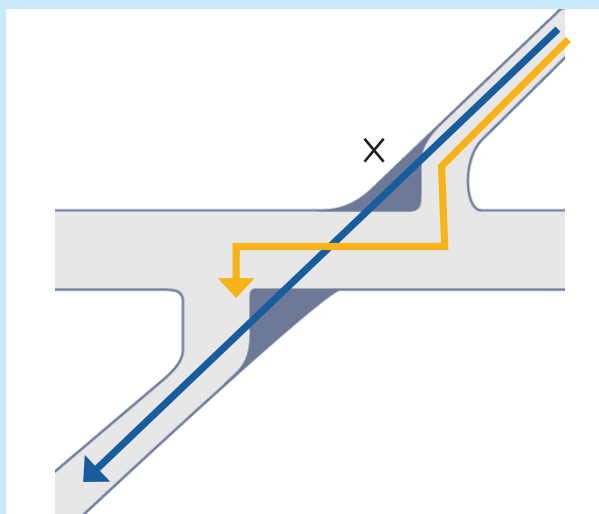

Source: © Alina F. Burlacu/GRSF/World Bank.

**Figure 6.16:** Convert offset T-intersections to four-leg + three-leg intersection (realign intersection approaches to reduce or eliminate intersection skew). Source: NACTO.

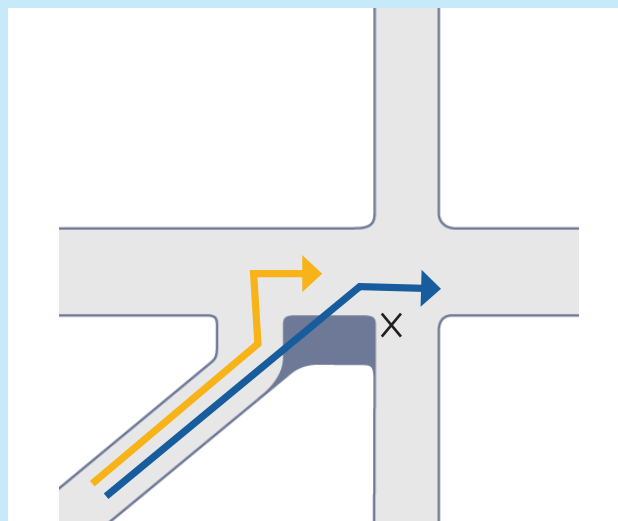

Source: © Alina F. Burlacu/GRSF/World Bank.

*Right-left staggered intersections (when left-side driving in the vehicle) induce shorter travel times than both left-right staggered intersections and four-leg intersections, in the sense that drivers coming from the minor road have to give way to only one traffic stream, i.e., when turning to the right onto the main road and then left into the minor road. However, this treatment could be detrimental to traffic operations when the offset between the two T-intersections is insufficient to allow main road traffic to react to slower moving vehicles.*

## 6.2. Signalized Intersections

### General description

A traffic signal controlled intersection restricts conflicting traffic movements in time or space by only allowing nonconflicting movements to proceed through the intersection at the same time. It controls vehicular and pedestrian traffic and assigns the right-of-way to the various traffic movements for a given duration, thereby profoundly affecting free traffic flow.

Traffic signals (figure 6.17) operate on the basis of phases and stages. A signal phase is a single movement stream that is assigned a green signal to move or a red signal to stop. Several phases can be combined to create a single signal stage. Once all phases have been allowed to proceed, a full signal cycle of movement through the intersection is completed.

Note: In some countries (e.g., Australia and New Zealand), the terminology is different with a “phase” being a period of time during which a set of traffic movements receive a green signal. This is equivalent to the concept of a “stage” in the UK and the US. One electrical output from the traffic signal controller is called a “signal group,” similar to the UK and the US concept of “phase.”

The amber signal is used to warn drivers of the approaching change in status between stop and go. The amber period is required to allow for driver reaction time and clearance of conflicting movements through the intersection. The potential conflict points vary by approach and size of the intersection.

The standard sequence of signal changes is:

Red: stop

Red and amber: prepare to go (used in only a small number of countries, including the UK)

Green: go

Amber: prepare to stop

Red: stop

Figure 6.17: Traffic control signal for vehicles in India.



Source: *Times of India*. 2016. Cops want 19 more road signals in city. July 20, 2016. <https://timesofindia.indiatimes.com/city/nashik/Cops-want-19-more-road-signals-in-city/articleshow/53296116.cms>.

Traffic signals are primarily for the control of motorized traffic but can include specific phases for pedestrian and cycle movement. The amount of time that each movement stream is given to proceed throughout the signal cycle is determined by knowing the amount of traffic that has to negotiate the intersection during a particular period. Different times can be given for different times of day or days of the week. The signals can either operate to a fixed time for each phase/stage/cycle or on “vehicle actuation” where minimum and maximum time periods for any stage can be varied depending on how many vehicles are needing to negotiate the intersection. This usually operates at times of low flow with fixed time plans being used at peak demand periods. The signal operational parameters are reviewed and updated (if needed) on a regular basis (as engineering judgment determines that significant traffic flow and/or land use changes have occurred) to maximize the ability of the traffic control signal to satisfy current traffic demands.

Where a road corridor encompasses two or more signalized intersections, these may be coordinated to achieve greater efficiency gains. In some countries, this principle may be used to create a “green wave” to prioritize a particular movement.



## Safety implications

- Appropriate phase control sequences can reduce the frequency and severity of certain types of crashes, especially right-angle collisions, by separating these from other conflicting movements, including pedestrians.
- The common practice of allowing nearside turns through a signal-controlled intersection can still result in substantial collision risk for crossing pedestrians.
- Traffic control signals are sometimes installed at locations where they are not needed, adversely affecting the safety and efficiency of vehicular, bicycle, and pedestrian traffic. The judgment of implementation of traffic control signals at an intersection must be done after consideration of alternatives (e.g., installing pedestrian beacon, roundabout, and so forth). (See section 6 on Intersection selection.)
- The improper or unjustified use of traffic signal control can result in:
  - i. Excessive delay,
  - ii. Disobedience of the signal indications,
  - iii. Increased use of inadequate routes to avoid the traffic signals, and
  - iv. Increases in the frequency of collisions (e.g., rear-end collisions).
- Furthermore, the possibility of increase in delays and noise and emissions should be considered.
- It is important to understand that installation of traffic control signals is not a “cure all,” and there may still be several risks (e.g., from noncompliance, lack of maintenance, remaining crashes, etc.).
- Visual obstructions of traffic signals and other traffic control devices should be removed. Traffic signals often are hidden by branches of a tree or

other obstructions. This makes urban travel particularly difficult and potentially life-threatening.

- Figure 6.18: Signal hidden by the branches of a tree in Gurudwara, India; tree/branches must be removed or replace signal.
- Source: Hindustan Times.<sup>136</sup>
- Land use, traffic, and other changes can cause existing traffic control signals to become obsolete or ineffective. Examples are harmful invisibility and grown branches of trees covering traffic signals (figure 6.18).
- Improper condition of signals makes it harder for road users to detect them and may be misleading. Dysfunctional signals during disasters or technical difficulties may cause issues (e.g., blackouts) because signals need electricity.
- Reduced conflict points for both vehicle-to-vehicle and vehicle-to-pedestrian can reduce certain types of crashes. For example, there are 32 vehicle-to-vehicle conflict points and 24 vehicle-to-pedestrian conflict points in a typical four-leg intersection

**Figure 6.18:** Signal hidden by the branches of a tree in Gurudwara, India; tree/branches must be removed or replace signal.



Source: Hindustan Times. 2019. Blocked vision, technical glitches of traffic lights in Gurugram fixed, April 5, 2019. <https://www.hindustantimes.com/gurgaon/blocked-vision-technical-glitches-of-traffic-lights-in-gurugram-fixed/story-3RV1I9hYpCjho4LCxXqO7I.html>.

136 Hindustan Times. 2019. Blocked vision, technical glitches of traffic lights in Gurugram fixed, April 5, 2019. <https://www.hindustantimes.com/gurgaon/blocked-vision-technical-glitches-of-traffic-lights-in-gurugram-fixed/story-3RV1I9hYpCjho4LCxXqO7I.html>.

**Figure 6.19:** All conflict points at four-leg intersection.

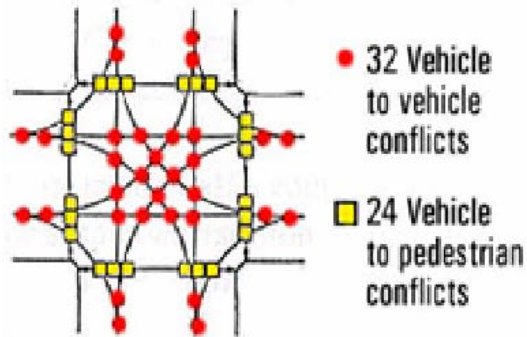

Source: Eugene R. 2019. *Operational Performance of Kansas Roundabouts: Phase II*. [https://www.researchgate.net/figure/Figure-Showing-the-Reduction-of-Conflict-Points-in-a-Roundabout-When-Compared-to-a\\_fig5\\_267548567](https://www.researchgate.net/figure/Figure-Showing-the-Reduction-of-Conflict-Points-in-a-Roundabout-When-Compared-to-a_fig5_267548567).

(figure 6.19). During a green light phase for pedestrians and vehicles approaching from the same direction, the number of vehicle-to-pedestrian conflict points can be reduced to only one if nearside turn on red is permitted (figure 6.20). Without that, ALL conflicts can be removed.

- Implementation of traffic control signals at unsignalized intersections reduced injury crashes by 30 percent according to a recent multi-country review.<sup>137</sup>

## Good design practice/ treatments/solutions

- Signal intersections simplify drivers' decision-making by preventing conflicting movements as illustrated in figure 6.21. The possibility of misjudging whether it is safe to enter or cross an intersection by both the vehicles on a minor street and pedestrians crossing the street can be reduced.
- Layout of traffic signals must be considered with the visibility of signals for road users. Driver's

**Figure 6.20:** Example of conflict points in specific phase at four-leg intersection.

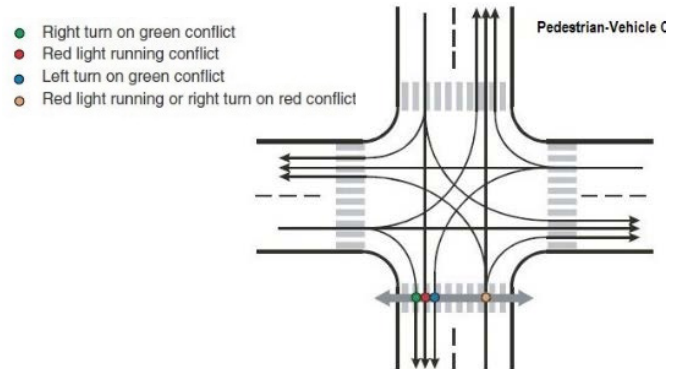

Source: National Cooperative Highway Research Program. 2010. Report 672 Roundabouts: An Informational Guide, Second edition.

sight triangle and the height of signals must also be considered.

- The signal head must also be visible at a point in the crosswalk which allows the pedestrian clear sight before and while crossing.
- Pedestrians must have sufficient time to travel (at 3.5 ft/s) to the center of the farthest travelled lane before crossing vehicles receive a green.<sup>138</sup>
- Periodical maintenance and consistency of power supply to traffic control signals is a recurring problem in LMICs (figures 6.22 and 6.23). When traffic signals are not working, their benefits are less effective, although vehicles do tend to use such intersections with more caution due to lack of certainty. The introduction of solar power offers a realistic and affordable option to a fixed power supply.
- Special attention for road users should be given if signals become dysfunctional or hidden.
- Alternative staging of signals can reduce all potential conflicts, but care is needed to maintain cycle times that do not result in users becoming impatient for change. Cycle times between 90 seconds to 2 minutes are preferred.

137 Turner, B., Steinmetz, L., Lim, A., and Walsh, K. 2012. Effectiveness of Road Safety Engineering Treatments. APR422-12. Austroads Project No: ST1571.

138 FHWA. 2019. The Manual on Uniform Traffic Control Devices.

Figure 6.21: Typical Signal Cycle for above stages.

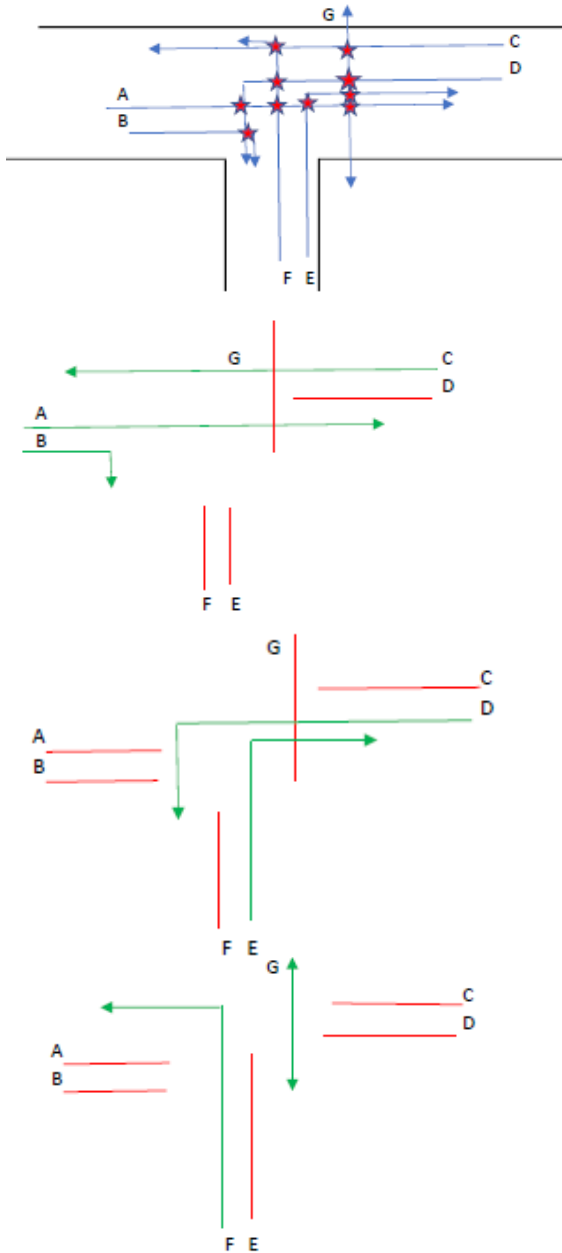

- A simple three-leg uncontrolled intersection with a pedestrian crossing on arm CD has 10 potential crossing points.
- All these can be removed under signal controls by preventing the conflicting movements operating together.
- By identifying each movement stream separately, alternative staging can be considered, depending on traffic volumes

**Stage 1**

- Green indicates those movement streams moving, and red indicates those movement streams stationary.
- The amber period between Stage 1 and 2 is required to allow phases A–D to clear the conflict point as being the longest.

**Stage 2**

- Green indicates those movement streams moving, and red indicates those movement streams that are stationary.
- The amber period between Stages 2 and 3 is required to allow phases D–F to clear the conflict point.

**Stage 3**

- Green indicates those movement streams moving, and red indicates those movement streams that are stationary.
- The amber period between Stages 2 and 3 is required to allow phases A–G to clear the conflict point.



Note: Pedestrian phase G requires green period to close before F to allow pedestrians to clear the roadway before the conflicting phase A starts.

Source: © John Barrell.

**Figure 6.22:** Intersection where signals are not functional in India



Source: Hindustan Times. 2016. Faulty traffic signals pose threat to city commuters, December 4, 2016. <https://www.hindustantimes.com/noida/faulty-traffic-signals-pose-threat-to-city-commuters/story-ldSjGgtFix-ievzSZ0MCp9M.html>.

**Figure 6.24:** Supplemental signal at horizontal curves.

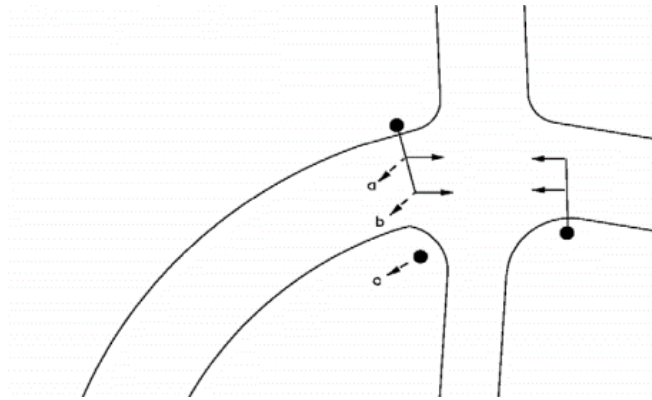

Source: FHWA, 2019.

## Signs and markings

- Supplemental pole mounted traffic signals may be placed on the nearside of intersections particularly where sight distance is an issue such as on approaches to intersections on curves (figures 6.24 and 6.25).
- In LMICs, motorists may crowd and stop too close to pedestrian crossings. Advanced stop lines at traffic signals are helpful in improving the visibility of pedestrians to motorists. Motorists may ignore the line if placed too far in advance of the pedestrian crossings (figure 6.26).
- At signalized intersections, advance stop lines back from the crosswalk at traffic signals must be placed away from the crosswalk to allow pedestrians and drivers to have a clear view of each other and more time in which to assess each other's intentions.<sup>139</sup>
- At large signalized intersections with multiple turn lanes, continuation of the lane markings through the intersection can provide additional guidance for motorists and reduce the occurrence of side impact collisions.

**Figure 6.23:** Dysfunctional signal in Dwarka, India.



Source: Times of India. 2019. Hidden traffic signals dangerous for drivers, April 25, 2019. <https://timesofindia.indiatimes.com/citizen-reporter/stories/hiddentrafficsignalsdangerousfordrivers/articleshow/69034168.cms>.

**Figure 6.25:** Supplemental signal for intersection in middle of reverse curve.

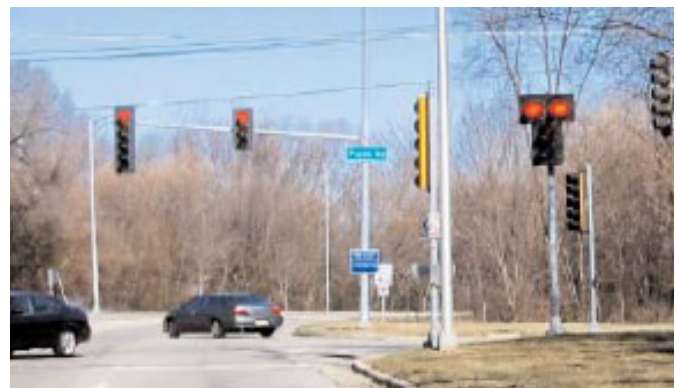

Source: Institute of Transportation Engineers. 2003. Making Intersections Safer: A Toolbox of Engineering Countermeasures to Reduce Red-Light Running.



**Figure 6.26:** Unsafe manner at stop line (overcrossing stop line).



Source: © Bahnfreund.

## Alternative devices

- There are several other types of traffic control devices which are similar to traffic signals controlling intersections. A pedestrian (hybrid) beacon is an example (figure 6.27). The difference of pedestrian beacons from pedestrian signals is that it remains dark over the traffic lanes unless a pedestrian pushes the crossing button, but it brings a higher rate of compliance on stopping traffic so pedestrians can cross much more safely. Early studies have shown up to 97 percent driver compliance, which is a better compliance rate by drivers than other devices at pedestrian crossings.<sup>242</sup>
- As a new innovation, signals on a crosswalk have been suggested (figure 6.28). This new form of traffic signal is fitted to the width of the road right before the zebra crossing. The lights are embedded into the road like reflector road signs and are waterproof. This signal works as a supplemental signal working with the traditional signals at the intersection when the visibility of the traditional traffic lights is obstructed by large vehicles, weather, and so forth. The effectiveness of this new type of traffic signal has been studied in New York, and the study team concluded signal lights

**Figure 6.27:** Pedestrian (hybrid) beacon in US.



Source: Federal Highway Administration. 2014. Pedestrian Hybrid Beacon Guide—Recommendations and Case Study. [https://safety.fhwa.dot.gov/ped-bike/tools\\_solve/fhwasa14014/](https://safety.fhwa.dot.gov/ped-bike/tools_solve/fhwasa14014/).

**Figure 6.28:** Pedestrian-cross-assistance devices (signals on cross walk) in Hyderabad, India.



Source: Anjani Kumar @CPHydCity/Hyderabad.

on pavement implies that it is more noticeable although not impossible to miss.<sup>140</sup>

## Signal phasing strategy and lane management

- The distribution of movement phases through the signal cycle is determined by analyzing the various road user demand flows through the intersection at various times of the day. The allocation of phases to different stages is then determined to minimize

## Case Studies/Examples

**Figure 6.29:** Traffic flows at unsignalized intersection without pedestrian crossings in Phnom Penh, Cambodia.

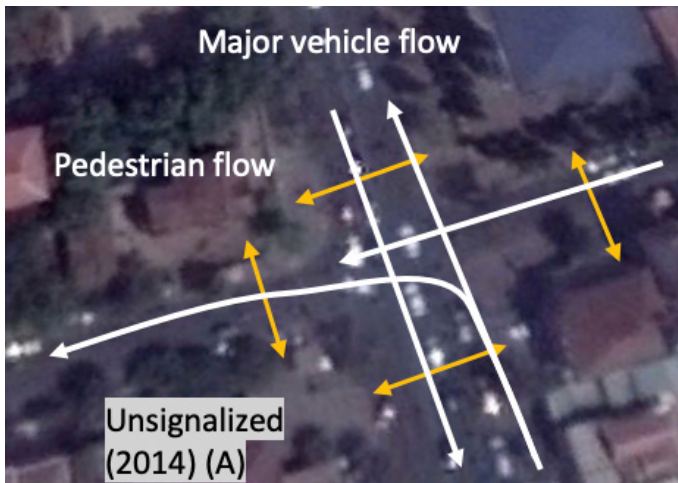

Source: © Google Earth.

overall delay and maximize safe operation. Timings for these stages are then developed through various simulations to determine the optimum timings for a given traffic pattern.

- Traffic signal phasing strategies can be adopted. The number of traffic control signal phases and their type and length are a significantly important factor on road safety at signalized intersections. The phases must be set by following references to appropriate consultations and manuals (e.g., FHWA, MUTCD).
- Signals for buses, trams, and cyclists can also be considered for road users' safety.
- Separately running phases on the same approach require a separate signal head to control the movement and appropriate lane management.
- Lane management is achieved through the use of traffic control devices that may include physical

**Figure 6.30:** Ordered traffic flow at signalized intersection with reduced conflict points.



Source: © Google Earth.

devices, static signs and road markings, electronic signs and markings, or colored pavement. Guidance on traffic control devices and their use is provided in Part 10 of the Guide to Traffic Management (Austroads 2019) and MUTCD.

Figures 6.29 and 6.30 illustrate vehicle-pedestrian conflict points in unsignalized intersections vs signalized intersections.

## Further Reading

- FHWA. 2019. The Manual on Uniform Traffic Control Devices.
- FHWA. 2013. Signalized Intersections Informational Guide, Second edition. <https://safety.fhwa.dot.gov/intersection/signal/fhwasa13027.pdf>.
- Austroads. 2019. Guide to Traffic Management Part 6: Intersections, Interchanges and Crossings.

## 6.3. Roundabouts

### General description

- A roundabout is a form of intersection channelization in which traffic circulates in one direction around a circular central island, and all entering traffic is required to give way to traffic circulating on the roundabout.
- Benefits include reduced conflict points and therefore driver workload associated with perpendicular junctions and, depending on traffic flows, reduced queuing associated with traffic lights.
- They provide facility for U-turns within the normal flow of traffic, which often are not possible at other forms of junction.
- When entering, vehicles only need to give way at relatively low speeds, and do not always perform a full stop. As a result, by keeping a part of their momentum, the intersection performs more efficiently from a traffic flow perspective. In addition, engines will require less effort to regain the initial speed, resulting in lower emissions. Research has also shown that slow-moving traffic in roundabouts makes less noise than traffic that must stop and start, speed up and brake.
- Originally roundabouts (sometimes referred to as traffic circles or rotaries) were designed with approaches that were both flared and tangential. This encouraged high speed and sometimes complex weaving maneuvers.
- Modern roundabouts were first standardized in the mid 1960s, with smaller diameter central islands, circulating space, and slower approaches. They were found to be a significant improvement over previous traffic circles and rotaries.
- Because low speeds are required for traffic entering roundabouts, they are physically designed to manage the speeds of traffic approaching and entering

the junction to improve safety. Approaches are designed so that vehicles enter the circulating carriageway with limited vehicle path radius naturally slow down.<sup>141</sup>

- Roundabouts can be used satisfactorily at a wide range of intersection sites, including:
  - i. Urban local and collector roads;
  - ii. Arterial roads in urban areas;
  - iii. Rural roads;
  - iv. Freeway/motorway ramp terminals; and
  - v. As a grade-separated treatment at an interchange.

### Safety implications

- Roundabouts provide a highly readable and consistent physical intersection layout that predictably and consistently limits the potential for higher speed and high impact angle conflicts.
- Transforming the control method from a two-way stop or traffic control signal to a roundabout with single/two lanes is effective in reducing the percentage of fatalities and injuries at intersections.
- For well-designed single lane roundabouts in particular, the rate of crashes between pedestrians and vehicles can be significantly reduced.
- By limiting the entry path curve and thereby introducing horizontal deflection to the approaches, vehicular entry speeds can be reduced, which provides drivers more time to react to potential conflicts and reduces crash severities.
- There are fewer vehicular conflict points and less potential for high severity conflicts, such as right-angle, left-turn, and head-on crashes because of the roundabout's design and because all drivers are going in the same direction.
- Generally, there is a reduced speed differential between vehicles travelling through the intersection, which reduces crash severity.

141 Austroads Guide to Road Design Part 4B, 2015, section 4.5.



- They are effective during power outages. Unlike traditional signalized intersections, which must be treated as all-way stop or require police to direct traffic, roundabouts continue to work as normal.
- As remaining safety risks, the following factors can be considered; however, because of the reliably low-speed environment, the severity of injuries from roundabout crashes, even for vulnerable users, tend to be low:
  1. **Misunderstandings of rules and not every driver knows roundabout rules.** In some countries/areas new to roundabouts, people have never learned the rules (yield and driving directions) of roundabouts. They might drive wrong directions and not yield to other vehicles;<sup>142</sup>
  2. **Poor judgement of gaps** by drivers entering a high-speed flow of circulating traffic, especially when there are multiple lanes;
  3. **Rear-end collisions** between vehicles waiting to join the roundabout may increase (although these are far preferable than the high-speed impacts seen at other intersection types);
  4. **Sideswipe collision** during changing lanes or entering/exiting the center circle;
  5. **Pedestrian/cycle collision** by not yielding to pedestrians and cyclists; and
  6. **Painted (or low height) islands become less visible and negligible for drivers.** Drivers may not make sense of what looks like painted circles on intersections that are meant to act as roundabouts.

## Good design practice/ treatments/solutions

- Properly designed roundabouts control the angle at which traffic enters the intersection and the speeds of vehicles entering and going through the intersection by creating geometric curvature with

center and splitter islands. This feature results in safer intersections than other at-grade intersections where vehicles can enter the intersection without slowing their speeds.

- Newer designs may also include raised platforms or humps on the approach that have been successfully used to slow the approach speed of vehicles, reducing the need for geometric curvature, and sometimes significantly reducing construction costs.
- Circulating space within the roundabout is often restricted to a single lane; however, multiple lanes can be used provided there is sufficient size to allow the inner flow of traffic to maneuver to the outer lane to exit. However, it should be noted that, as circulating widths increase, the ability to control speed into and through the roundabout becomes less predictable.
- A key element of safe roundabout operation is to ensure that the central island or splitter islands provide sufficient deflection from the straight-ahead movement to ensure slow vehicle speeds through the intersection (see figure 6.31 for an example of a poorly designed roundabout). Where sufficient deflection is not possible (for instance due to restrictions in road space), raised platforms have been used successfully instead.

**Figure 6.31:** Dangerous roundabout design in Romania, where the main road has no deflection.



Source: Google street view.

142 Bhutanese. <https://thebhutanese.bt/virtual-roundabouts-remain-ignored-by-motorists/>. Accessed on 11/13/2019.



**Figure 6.32:** Vehicle ignoring flat roundabout in Croatia

Source: Novilist.hr

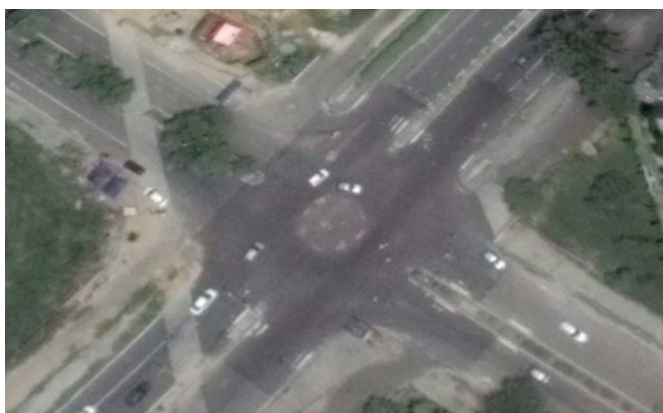
**Figure 6.34:** Roundabout with too small center island in India.

Source: © Google Earth.

- With splitter islands, pedestrians are required to cross only one direction of traffic at a time at a roundabout and contend with slower-moving vehicles because of the splitter islands.
- Flat/low height islands (i.e., marking) may not work (figure 6.32). Center and splitter islands should be physically raised to provide readability.
- Decoration and vegetation at center and splitter islands must not obstruct driver's sight distance of approaching or circulating traffic (figure 6.33). However, it should be sufficiently high to obstruct the straight through view of the road ahead and concentrate drivers' awareness on the roundabout.
- The center island and the splitter islands must be large enough to force approaching vehicles to reduce their speed in order to enter the

**Figure 6.33:** Decorated roundabout obscuring driver's sight in Bhutan

Source: The Travel Magazine.

**Figure 6.35:** Inappropriate location and size of roundabout in Bhutan.

Source: Kuensel.

- intersection. Too small center islands and splitter islands may not work to reduce the speed of approaching vehicles during passing through the intersection because turning along the center island is not required (figures 6.34 and 6.35). This defeats the purpose of a roundabout.
- A key factor in determining the size of a roundabout, both the central island and the width of the circulating carriageway, is the safe negotiation of the design vehicle for all movements. For example, when designing for the safe passage of a semitrailer unit, as the central island radius decreases, so the circulating width must increase to allow the vehicle to get around the island. This effect depends on the vehicle dimensions and hinge point. Because this can result in less deflection and therefore higher negotiation speeds, it may be preferable to

**Figure 6.36:** Diameter and length adjustment of islands in a roundabout.

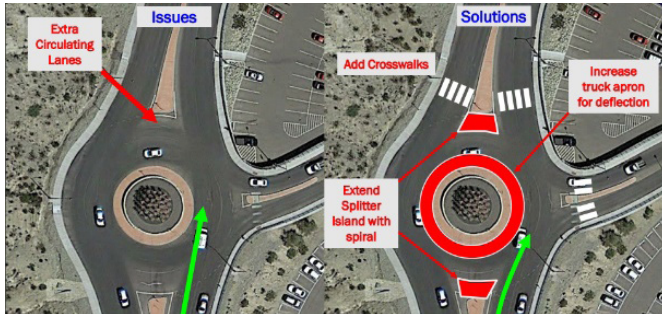

Source: Gus S. 2018. *Are Multilane Roundabouts a Safe and Effective Intersection Treatment*, 2018 ITE Joint Western & Texas District Annual Meeting. [https://www.westernite.org/annualmeetings/18\\_Keystone/Presentations/3B/3B.Randy%20Johnson.Multi-lane%20Roundabouts.Johnson-Berger-Sanchez.pdf](https://www.westernite.org/annualmeetings/18_Keystone/Presentations/3B/3B.Randy%20Johnson.Multi-lane%20Roundabouts.Johnson-Berger-Sanchez.pdf). Accessed on 11/14/2019.

**Figure 6.37:** Truck apron with correct design for use by trucks only with a narrow circular carriage in South Africa.



Source: Southern African Transport Conference 2017.

**Figure 6.38:** Truck apron not serving the purpose of design in South Africa (too high apron to ride on for larger trucks and too low to block riding on passenger cars).



Source: Southern African Transport Conference 2017.



provide a slightly raised apron or ever-run area on the central island. With a low vertical lip (50 mm), this feature allows the large vehicles to negotiate safely while still providing a narrower “target” for small vehicles, and maintains predictability.

- A traversable truck apron can be provided at roundabouts to accommodate large vehicles while minimizing other roundabout dimensions (see figures 6.36 through 6.38). A truck apron provides an additional paved area to allow the over-tracking of large semitrailer vehicles on the central island without compromising the deflection for smaller vehicles. At the roundabouts which do not have truck aprons, the circulatory lanes become too wide to accommodate larger vehicles. This can cause an

inappropriate usage of lanes. These roundabouts have higher vehicle speed through the intersection.

- Humps and platforms can be used to reduce speeds, especially where there is not enough deflection on approach.
- Pedestrian and cyclist facilities can be included in the intersection design (references to earlier chapters on this).
- Education may be needed to ensure road users know how to navigate roundabouts, especially when first introduced; and to enforcement to ensure compliance. A small center island and a lack of length of splitter islands will also make extra circulating lanes.



**Figure 6.39:** Roundabout (rotary) with improper lane alignment and width creating extra lanes in Serbia.



Source: The Miner (CC BY-SA 3.0).

**Figure 6.41:** Mini-roundabout with noticeable pole—Zagreb, Croatia.



Source: © Admiral Norton.

- Lane lines must be provided with appropriate widths. Sometimes lane lines of roundabouts are missing (figure 6.39). Approaching vehicles will miss the courses they should drive in the intersection, and consequently crashes between vehicles will be caused. The lane boundaries must be provided as per the approaching roads. This can also guide vehicles to turn along the center island appropriately and reduce their speed.
- In low speed, constrained urban environments mini-roundabouts—those with no physical island and only a painted circular road marking—can be effective if flows are low and speed is well controlled. Deflection though the intersection

**Figure 6.40:** Mini-roundabout (Wetherby, England).



Source: © John Barrell

is provided through traffic rules and approach alignments that require the central marking to be passed to the offside.

- Mini-roundabouts (figures 6.40 and 6.41) may be an optimal solution for a safety or operational issue at an existing stop-controlled or signalized intersection where there is insufficient right-of-way for a standard roundabout installation. Mini-roundabouts are characterized by a small diameter and mostly traversable (painted circle or low dome) islands (central islands and splitter islands) and offer most of the benefits of regular roundabouts with the added benefit of a smaller footprint.<sup>143</sup> Mini-roundabouts should be installed at only low-speed and low-volume roads because they do not have a physical coercive function to slow and curve vehicles going through the intersection.
- Signage for indication of a roundabout ahead in a clear and consistent way throughout the network is very important. The variation in the use of signs and markings (figure 6.42) reflects either the lack of knowledge, the lack of attention to detail, or the lack of clear guidance for the implementation of road signs and road markings. Similarly, the variation of road markings also causes driver's misbehaviors.
- The performance of some congested roundabouts

**Figure 6.42:** Good quality roundabout sign but variation of sign in the same country confusing drivers in South Africa.



Source: Southern African Transport Conference 2017.

can be improved with traffic signal control by balancing entry flows and/or a continual flow of traffic on the circulating carriageway to prevent long queues causing long delays and blocking back into preceding junctions. Signals are able to keep the circulatory traffic flow fluid and hence balance and improve the roundabout capacity.<sup>144</sup>

- The number of pedestrians (and cyclists) can increase crash risks and delays because traffic is governed by yield-control entry at a roundabout, especially at intersections with a low volume of

pedestrians. Providing specific crossing points and routes around the intersection separate from motorized traffic can improve pedestrian and cycle safety at roundabout intersections (see section 4 on Vulnerable users).

- Traffic rules and design of roundabouts must coordinate with other transportation modes to avoid increasing crash risks in arterial roads with cycle lanes and public transportation lanes (see section 4.5 on Public transport).

144 Department of Transport UL. 2009. Signal Controlled Roundabouts.



## Case Studies/Examples

Figures 6.43 through 6.47 show examples of roundabouts in various contexts.

**Figure 6.43:** Roundabout which allows larger vehicles to mount part of central island (same conditions of mini-roundabouts applied).



Source: Imagic (CC BY-SA 2.0).

**Figure 6.44:** Roundabout with tram rails in Poland.

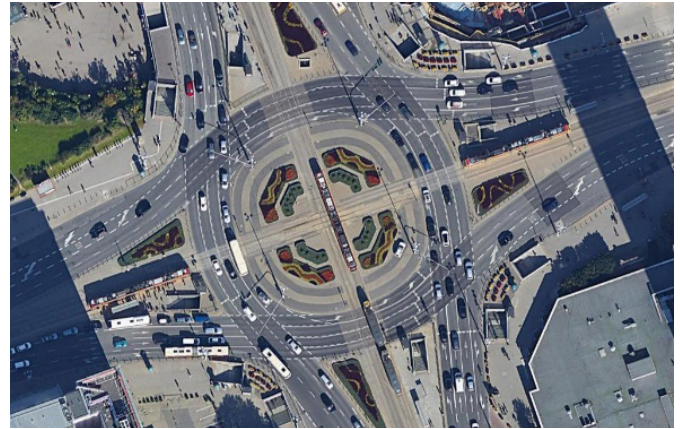

Source: © Google Earth.

**Figure 6.45:** Transformation from uncontrolled intersection to roundabout—The Philippines.

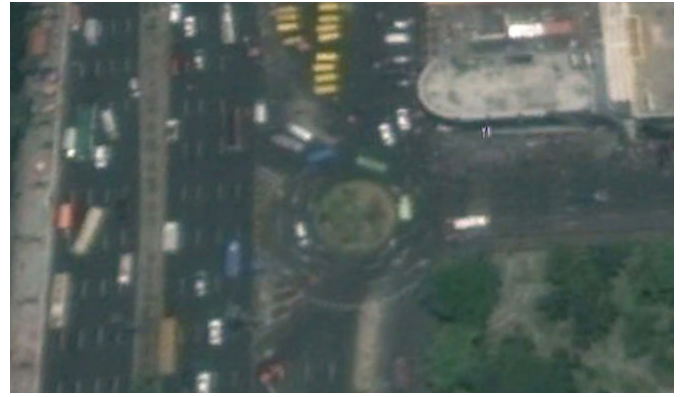
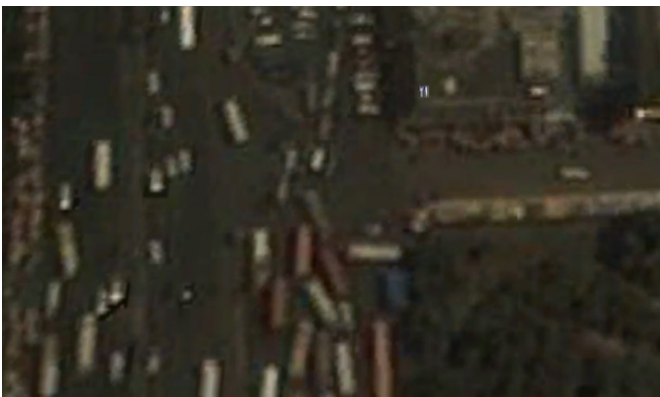

Source: © Google Earth, Top Gear Philippines.

**Figure 6.46:** Example of low-cost roundabout in Argentine



Source: Municipalidad Chivilcoy @MuniChivilcoy

**Figure 6.47:** Example of mini-roundabout with reflection in Italy.



Source: © Mad Vinyl.

## Further Reading

- FHWA. 2009. *The Manual on Uniform Traffic Control Devices*. Must read chapter 2B, Regulatory signs, barricades, and gates; chapter 3C, Roundabout markings.
- FHWA. 2010. *Roundabouts: An Informational Guide, Second Edition* (NCHRP Report 672). [https://www.virginiadot.org/business/resources/NCHRP\\_Report\\_672\\_Roundabout\\_Informational\\_Guide\\_2nd\\_Edition2010.pdf](https://www.virginiadot.org/business/resources/NCHRP_Report_672_Roundabout_Informational_Guide_2nd_Edition2010.pdf).
- Tomaž T. 2016. Comparative Analysis of Four New Alternative Types of Roundabouts: “Turbo,” “Flower,” “Target,” and “Four-Flyover” Roundabout, 60(1), pp. 51–60.
- Austrods. 2018. *Towards Safe System Infrastructure A Compendium of Current Knowledge*, Research Report AP-R560-18. Must read chapter 5, Harm minimization at intersections.
- FHWA. 2007. Roundabouts in the United States (NCHRP Report 572). <https://nacto.org/docs/usdg/nchrprpt572.pdf>.
- Conference of European Directors of Roads. 2008. *Best Practice for Cost-Effective Road Safety Infrastructure Investments*. Must read chapter 3, Review of road safety investment and chapter 5, In-depth analysis of most promising road safety investments.
- FHWA. 2010. Mini-Roundabouts. <https://www.fhwa.dot.gov/publications/research/safety/00067/00067.pdf>.
- Department of Transport UL. 2009. Signal Controlled Roundabouts. [https://assets.publishing.service.gov.uk/government/uploads/system/uploads/attachment\\_data/file/876622/ltn-1-09\\_Signal\\_controlled\\_roundabouts.pdf](https://assets.publishing.service.gov.uk/government/uploads/system/uploads/attachment_data/file/876622/ltn-1-09_Signal_controlled_roundabouts.pdf).
- FHWA. 2010. *Highway Capacity Manual 2010 (HCM2010)*. Must read chapter 4, Unsignalized intersection.
- FHWA. 2014. *Kansas Roundabout Guide, Second Edition (A Companion to NCHRP Report 672)*. [https://www.ksdot.org/Assets/wwwksdotorg/bureaus/burtrafficeng/Roundabouts/Roundabout\\_Guide/KansasRoundaboutGuideSecondEdition.pdf](https://www.ksdot.org/Assets/wwwksdotorg/bureaus/burtrafficeng/Roundabouts/Roundabout_Guide/KansasRoundaboutGuideSecondEdition.pdf).
- Abishai P. 2005. *Evaluation of Roundabouts versus Signalized and Unsignalized Intersections in Delaware*. <https://cpb-us-w2.wpmucdn.com/sites.udel.edu/dist/1/1139/files/2013/10/Rpt.-179-Roundabouts-Final-11329b7.pdf>.
- NCHRP. 2020. Report 672 Roundabouts—An Informal Guide, 2nd edition. <http://onlinepubs.trb.org/onlinepubs/webinars/RoundaboutsPresentations.pdf>.



## 6.4. Raised Intersections

### General description

A raised intersection is a speed management treatment and is designed to achieve speed reductions or reinforcement for vehicles approaching an intersection by raising the entire intersection to sidewalk level or a similar level. The flat raised areas cover the entire intersections, with ramps on all approaches and often with brick or other textured materials on the flat section and ramps. Vehicles passing through a raised intersection must ascend on the approach to, and descend on the departure from, the intersection.

They are sometimes referred to as raised junctions, intersection humps, or plateaus and are similar to speed humps and other vertical speed control elements. They reinforce slow speeds and encourage motorists to yield to pedestrians at the crosswalk. As the roadway is raised to sidewalk level there is usually no need to identify specific crosswalk locations, and such arrangements are suitable for low-speed, low-flow roads.

### Safety implication

- Research has found the most effective traffic-calming measures to involve vertical shifts in the roadway, such as speed humps, speed cushions, and speed tables (gateway treatments).<sup>145</sup>
- Similar to speed humps, raised intersections result in creating a safe, slow-speed crossing and encourage vehicles to yield to pedestrians at the crosswalk (see section 3.2 on Speed compliance and traffic calming).
- Raised intersections can typically reduce the speed of approaching vehicles by less than 10 percent.<sup>146</sup> Therefore, they are more reliable to emphasize or

reinforce a limit rather than in achieving a speed reduction.

### Good design practice/ treatments/solutions

- Raised intersections (see figures 6.48 through 6.51) are most appropriate for undivided carriageways, sites with small footprints, where high pedestrian movements are expected, or pedestrians have increased priority. However, installing approach platforms or humps on an undivided carriageway is not recommended, as it may result in drivers switching into the opposing lane to avoid them unless they extend across the full width of the carriageway.
- Raised intersections have been implemented at mostly minor intersections but have not been widely implemented on arterial roads or at intersections with higher speeds.
- Constructing raised intersections should be avoided at sites with notable horizontal or vertical curves that may impede sight lines to raised intersections and associated signing, as well as with vertical clearance restrictions.
- Raised ramps must be orientated perpendicular to the direction of traffic flow to ensure both front wheels of a vehicle begin to rise or fall on the ramps concurrently. Should this not occur, vehicles may traverse the ramps with wheels at different levels, potentially causing instability and affecting the driver's ability to safely operate the vehicle. This is a particular concern for two-wheeled vehicles turning at corners.
- Raised intersections must adopt a flat top profile, and their approach and departure ramps should be also flat with the same consistent grade.
- The flat section (i.e., the plateau) of a raised intersection must have a minimum of 6 m in the road

145 FHWA. 1998. Synthesis of Safety Research Related to Speed and Speed Management.

146 Institute of Transport Engineering. 2019. Traffic calming measures. <https://www.ite.org/technical-resources/traffic-calming/traffic-calming-measures/>.

**Figure 6.48:** Raised intersection in Bogotá to give priority to pedestrians on an arterial street.



Source: © Ben Welle/WRI.

**Figure 6.50:** Raised intersection with different pavement pattern.



Source: Northeastern University

**Figure 6.49:** Raised intersection with colored pavement.

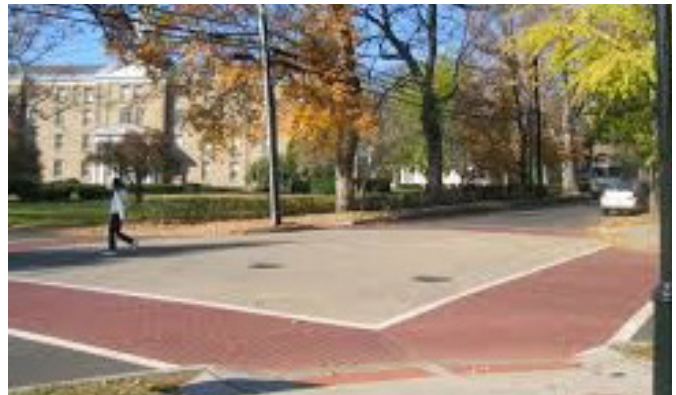

Source: NACTO.

**Figure 6.51:** Segregating conflict points in stages.

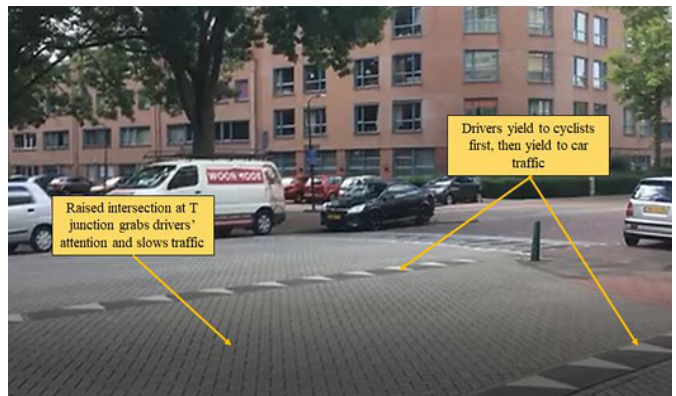

Source: Northeastern University

width to store a standard passenger vehicle, including when used as a pedestrian crossing. When raising an entire intersection, this width will extend to encompass the intersection footprint.

- The desirable height of a raised intersection's platform is 100 mm, but 75 mm may be considered where site constraints and traffic composition suggest a lower height profile is suitable (e.g., high truck or bus volume routes). Ramp heights < 75 mm are much less effective at reducing speeds and should not be considered. For low speed (< 50 km/h) and low traffic volume environments, 150 mm may be used; however, platforms > 100 mm in height may damage low-floor vehicles and are not

recommended on arterial roads<sup>147</sup> (see section 5.5 on Vertical alignment).

- Departure ramps should be designed as a smooth exit from a raised intersection. Based on the trials in Victoria, a 1:35 grade is considered appropriate for the departure ramp. Flatter slopes may also be considered.
- The grade of the ramp must be adjusted to achieve an equivalent change in grade when constructing raised intersections ramps on an upgrade or downgrade.
- Beside their construction costs, potential impacts on services and drainage must be considered (see section 5.11 on Drainage).



- Constructing raised ramps should not be placed where lane changing is necessary or frequent (e.g., at or beyond directional signs). When installed on turning lanes, raised ramps must be placed in a location that allows a turn to be commenced, or completed, prior to crossing the ramp.
- To avoid drivers misinterpreting where to stop prior to entry into a raised intersection, stop lines must be located either:
  1. Prior to the beginning of the raised intersection ramp (preferred), or
  2. On the platform, prior to the beginning of the departing ramp (for platforms) or pedestrian crossing (for raised intersections).
- A minimum clearance of 7 m is required between the start of the platform plateau or base of the platform slope and stop line to ensure a standard passenger vehicle can comfortably be stored in advance of the stop line. Similarly, where the percentage of heavy vehicles using the road is high, locating approach ramps the equivalent length of the critical stability vehicle prior to the turning point must be considered.
- Location and orientation of the approach and departure ramps to avoid the critical vehicle instability;
- Maximum raised intersection height to avoid critical vehicle instability;
- Potential operational deficiency and delays due to the lower acceleration and deceleration of heavy vehicles; and

Potential implications of larger vehicle drivers using alternate routes (e.g. local streets) to avoid the raised intersection.

#### Markings and signs

- All raised intersections should have warning signs (figures 6.52 and 6.53) with a recommended advisory speed based on a safe speed (figure 6.54).
- Where vehicle stability concerns exist, installing warning signs with an appropriate truck tilting advisory speed should be considered (figure 6.55).
- The introduction of raised intersections may lessen the conspicuity between road space and pedestrian space, particularly when proposed platforms are flush with adjacent land. Additional delineation such as contrasting colored pavement marking and/or white curbside linemarking may be considered to improve the conspicuity of the raised intersection (figures 6.56 through 6.58). These visual enhancements of intersections can also contribute to a driver's recognition of intersections.

### Larger vehicles

The following are key considerations for larger vehicles, including buses, emergency vehicles, and so forth:

**Figure 6.52:** Raised intersection with stop sign.

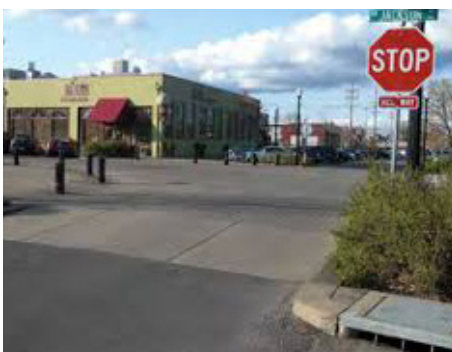

Source: © City of Albuquerque.

**Figure 6.53:** Raised intersection with crossing sign.



Source: © City of Albuquerque.

**Figure 6.54:** Warning signs with a recommended advisory speed.

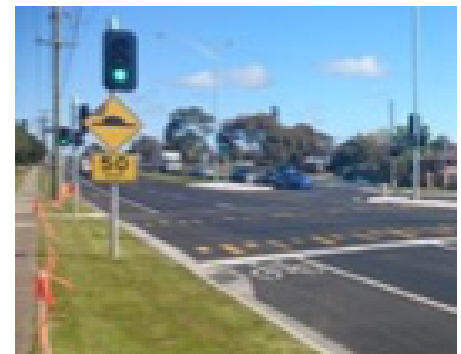

Source: Vicroads.

**Figure 6.55:** Truck tilting warning signs with advisory speed.



Source: Vicroads.

**Figure 6.57:** Colored, raised intersection with line markings.

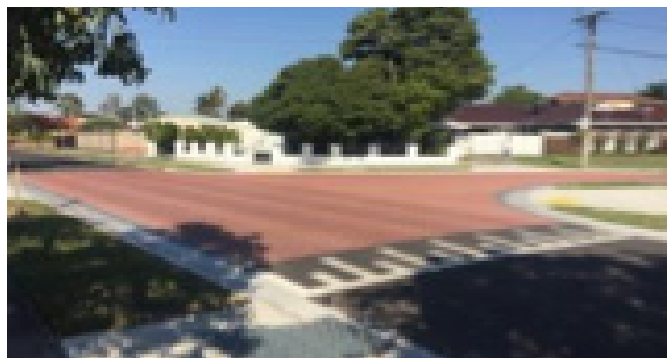

Source: Vicroads.

### Measures for higher speed roads

To achieve appropriate speed reduction for vehicles approaching an intersection on a higher-speed road environment ( $\geq 80$  km/h), it is not practical to use raised intersections alone. Therefore, consideration shall be given to adopting supporting treatments such as, but not limited to:

- Speed reduction in stages (e.g., multiple platforms with appropriate ramp profiles);
- Permanent speed limit reduction (supported by other treatments including platforms and speed cameras when required);
- Additional warning signs (e.g., flashing warning signs);
- Speed calming line marking;
- Transverse rumble strips; and
- Gateway treatments.

**Figure 6.56:** Low cost marked intersection.

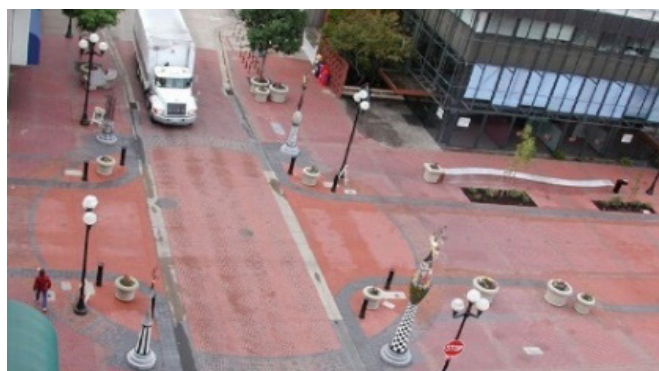

Source: NACTO.

**Figure 6.58:** Marked intersection with artistic design to attract more driver's attention.

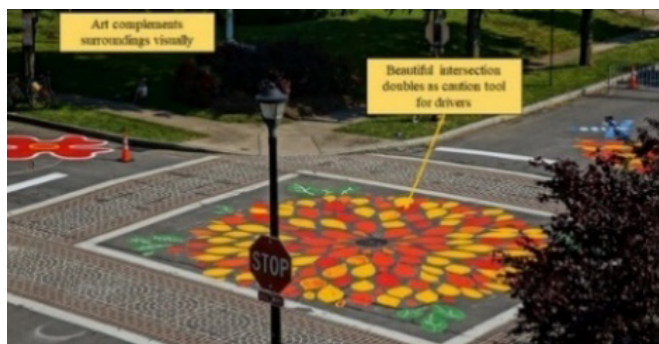

Source: Northeastern University.

### Further Reading

- Austroads. 2019. Guide to Traffic Management Part 6.
- NACTO. 2019. Urban Street Design Guide. <https://nacto.org/publication/urban-street-design-guide/>.
- FHWA. 2017. Traffic Calming ePrimer. [https://safety.fhwa.dot.gov/speedmgt/traffic\\_calm.cfm](https://safety.fhwa.dot.gov/speedmgt/traffic_calm.cfm).
- Vicroads. 2019. Road Design Note: Raised Safety Platforms. <https://www.vicroads.vic.gov.au/-/media/files/technical-documents-new/road-design-notes/road-design-note-0307--raised-safety-platforms-rsp-version-c2.ashx>.

## 6.5. Channelization (including turn/slip lanes)

### General description

Channelization is the provision of dedicated traffic lanes for different movements at intersections. It aims at improving the performance and safety of intersections by separating traffic flows (either through road marking or physical islands) and making driving patterns and right-of-way rules transparent. Such channelization can reduce the area of conflict as well as improve intersection angles. It may also be added to increase capacity, improve the visibility of traffic control devices, and reduce crashes. It can be included in all types of intersections, irrespective of layout or control.

Channelization can be included on both/or side roads and main roads. Separation of movements can be with traffic islands, medians, or road markings, together with auxiliary lanes or designating lanes for specific movements such as left-turn, right-turn, or U-turn.

These lanes can also be referred to as turn lanes or slip lanes. In some countries, turn lanes refer to the offside channelized turning lane that provides a waiting area for turning traffic while they wait for a suitable gap in the opposing traffic. Slip lanes to the nearside turning lane provide a dedicated deceleration facility that removes the slowing traffic from the through traffic. These may be free-flow or required to give way to other traffic once the side road is reached.

The tapered area of these lanes on the approaches to intersections function as storage lanes for turning traffic. Associated auxiliary lanes can also serve as a useable shoulder for emergency use and to accommodate stopped vehicles. Normally these lanes should be installed as separate lanes (not overtaking lanes) from traffic which is going straight ahead at an intersection, so that this traffic can pass vehicles which are waiting to turn.

Large-scale channelization is not a solution for every problem. Improper or excessive channelization can reduce safety and capacity. Many times the addition of a turning lane, median, or island is sufficient to accomplish the desired improvements. With the added conflict of railroad traffic, care must be taken to ensure that channelization provides guidance and control, not confusion.

Inappropriately designed channelized turning lanes can result in not increasing capacity very much and making crossing difficult for cyclists and pedestrians. A channelized near-side lane (deceleration slip lane) is primarily aimed at improving efficiency. From a safety perspective it is contrary to safe system principles if it allows through traffic to increase their speed through the intersection and creates high-speed, large radius slip lanes, rather than through traffic slowing behind the slowing, turning vehicle. In addition, if the slip lane (deceleration lane) is not adequately separated from the through traffic, there is a high risk that vehicles using that lane could mask or hide vehicles in the through lane. This is sometimes referred to as the “shadowing effect” or “dynamic visual obstruction” and represents a significant increase in risk for a vehicle turning out of the side road (figure 6.59).

**Figure 6.59:** Shadowing effects (dynamic visual obstruction)—a large vehicle in the slip lane hiding a vehicle in the through lane.



Source: Woolley, J., Stokes, C., Turner, B., and Jurewicz, C. 2018. *Towards safe system infrastructure: a compendium of current knowledge* (No. AP-R560-18).

## Safety implication

- A primary goal of intersection design is to limit and/or reduce the severity of potential road user conflicts.
- FHWA clarifies that the basic principles of intersection channelization that can reduce conflicts are:
  1. **Separate points of conflict.** Separation of conflict points can ease the driving task while improving both the capacity and safety at an intersection. The use of exclusive turn lanes, channelized right turns (for those driving on the right), and raised medians as part of an access control strategy are all effective ways to separate vehicle conflicts. (see section 6.6 on Left-in left-out/right-in right-out).
  2. **Define desirable paths for vehicles.** The approach alignment to an intersection as well as the intersection itself should present the roadway user with a clear definition of the proper vehicle path at risky locations with complex geometry or traffic patterns, such as highly skewed intersections, multi-leg intersections, offset T-intersections, and intersections with very high turn volumes. Clear definition of vehicle paths can minimize lane changing and avoid “trapping” vehicles in the incorrect lane.
  3. **Discourage undesirable movements.** Designers can utilize corner radii, raised medians, or traffic islands to prevent undesirable or wrong-way movements, including restriction of turns and designing approach alignment to facilitate intuitive movements.
  4. **Encourage safe speeds.** On low-speed roads with pedestrians, turning speeds should be lower by smaller turning radii, narrower lanes, and/or channelization features (figure 6.60). On high-speed roads with no pedestrians, speeds for turning vehicles should be comparable with straight through speeds to remove turning vehicles from the through traffic stream as quickly and safely as possible. This can be accomplished with longer, smooth tapers and with associated deceleration length to corner at a slower speed.
  5. **Facilitate the movement of high-priority traffic flows.** Accommodating high-priority movements at intersections addresses both drivers’ expectations and intersection capacity. The highest movement volumes at an intersection define the highest priority movements, although sometimes route designations and functional classification of intersecting roads should be considered. In low density suburban and rural areas, giving priority to motor vehicle movements may be appropriate; however, in some urban locations, pedestrians and cyclists at times may be the highest priority users of the road system. Separating movements by channelization can reduce crossing widths for pedestrians and increase their opportunity to cross busy roadways.

**Figure 6.60:** Angle of slip lane transformed from wide (left picture) to tight (right picture)

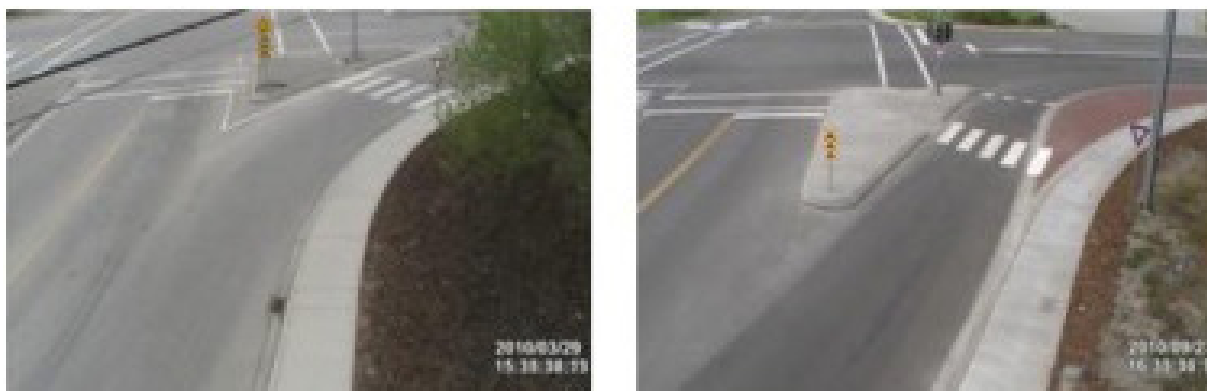

Source: Javus, A. et al. 2012. Safety evaluation of right-turn smart channels using automated traffic conflict analysis, *Accident Analysis & Prevention*, Volume 45, March 2012, pages 120–130.



6. **Facilitate the desired traffic control scheme.**

Visibility of signs and markings at intersections can be maintained by channelization. Other equipment at the intersection should not block sight distance and should facilitate preventive maintenance by field personnel. Intersection layout should be designed for simultaneous left-turning movements and potential U-turning movements. Operational impacts and the design of pedestrian facilities should be taken into account during the intersection's design.

7. **Accommodate decelerating, slow, or stopped vehicles outside higher-speed through traffic lanes.**

Speed differentials between vehicles in the traffic stream are a primary cause of crashes. Speed differentials at intersections are inherent as vehicles decelerate to facilitate turning. The provision of exclusive left- and right-turn lanes can improve safety by removing slower-moving turning vehicles from the higher-speed through traffic stream and reducing potential rear-end conflicts. In addition, through movements may experience lower delays and fewer queues. However, care is needed not to induce higher speeds for through and turning traffic and obscure the view for side-road traffic

8. **Provide safe refuge and way finding for cyclists and pedestrians.**

Intersection channelization can provide refuge and/or reduce the exposure distance for pedestrians and cyclists within an intersection without limiting vehicle movement.

- Channelization separating through and turning lanes may constitute a hazard because of its placement when a raised treatment is applied,

especially on high-speed roads.<sup>148</sup>

- Channelized offside turn lanes can make speed on intersection approaches slower than non-channelized nearside turn lanes.<sup>149</sup>
- Several studies from high-income countries confirm that the provision of turn lanes has been found to reduce crash rates.<sup>150, 151, 152</sup>

Some studies proved the effectiveness of channelization.

- The provision of median islands on the approach to an intersection can assist drivers to identify the location of the intersection and raise their alertness to select their travel path through the intersection. Median islands provide some protection for turning vehicles when a turning lane is provided to take the turning vehicle out of the through lane. This treatment can achieve a reduction in head-on, rear-end, and right-turn type crashes by 20 percent. If the median island is placed through the intersection, thereby removing the cross-movement, head-on, right-turn and right-angle type crashes can be eliminated.
- For wider medians (generally more than 5.4 m [18 ft]), offsetting the turn lane provides the following safety benefits:
  1. Better visibility of opposing through traffic;
  2. Decreased possibility of conflict between opposing left-turn movements within the intersection; and
  3. More left-turn vehicles served in a given period of time, particularly at a signalized intersection.<sup>153</sup>
- The provision of indented turn lanes with painted

148 Vicroads. 2019. Road design notes: Raised Safety Platforms (RSPs).

149 FHWA. 2014. Handbook for Designing Roadways for the Aging Population: Accessed at [https://safety.fhwa.dot.gov/older\\_users/handbook/](https://safety.fhwa.dot.gov/older_users/handbook/).

150 Staplin, et al. 1997. National Highway Traffic Safety Administration.

151 Gluck, J., H. S. Levinson, and V. Stover. 1999. National Cooperative Highway Research Program Report 420: Impacts of Access Management Techniques. NCHRP, Transportation Research Board, Washington, DC.

152 Elvik, R., Høy, A., Vaa, T., and Sørensen, M. 2009. The Handbook of Road Safety Measures, Second edition. Emerald Group Publishing Limited. ISBN 978-1-84855-250-0.

153 Harwood, D. W., M. T. Pietrucha, M. D. Wooldridge, R. E. Brydian, and K. Fitzpatrick. 1995. National Cooperative Highway Research Program Report 375: Median Intersection Design. NCHRP, Transportation Research Board, Washington, DC.

islands can achieve a 20 percent reduction in opposing turn and rear-end crashes; and with a median island, reductions of 40 percent in rear-end, 30 percent opposing turn, and 20 percent loss-of-control crashes can be achieved.<sup>154</sup>

- An Australian meta-analysis shows a reduction range from 22 percent to 36 percent of crashes. This reduction is for channelization where it is not clear whether it is a splitter, median, or both. Five studies of splitter islands again showed an overall reduction of about 30 percent; two studies of reductions due to median islands showed a reduction of about 20 percent. These benefits may be captured as part of other attributes, such as turn lane provision and delineation.
- Crashes at signalized intersections where a right offside turn lane (in right-hand traffic) was added, in combination with and without a right-turn separate signal phase, were reduced by 36 percent and 15 percent, respectively. At non-signalized intersections with marked channelization separating the right offside turn lane from the through lane, crashes were reduced for rural, suburban, and urban areas by 50, 30, and 15 percent, respectively. When raised channelization devices were used, the crash reductions were 60, 65, and 70 percent in rural, suburban, and urban areas, respectively. Consistent findings were reported in Hagenauer et al. (1982),<sup>121</sup> McFarland et al. (1979),<sup>122</sup> and FHWA (2014). Handbook for Designing Roadways for the Aging Population. Accessed at [https://safety.fhwa.dot.gov/older\\_users/handbook/](https://safety.fhwa.dot.gov/older_users/handbook/).

## Good design practice/ treatments/solutions

- Raised channelization with sloping curbs is recommended over channelization accomplished through the use of pavement markings alone (flush) for left- and right-turn lane treatments at intersections on

all roadways with operating speeds of less than 20 km/h. (AASHTO 2009. *Highway Safety Manual*).

- Raised islands should be semi-mountable curbs. Barrier curbs and other profiles are not favored for use on islands. Depressed islands can also be outlined using curbs, provided that adequate definition and delineation of the island can be achieved by other means (e.g., berm behind the curb).
- Prohibited turns should be blocked by channelizing islands, wherever practical.
- Islands/medians should be conspicuous to approaching drivers. Rural sites with few constraints will have relatively large islands (e.g.,  $\geq 100$  m<sup>2</sup> for a splitter island on an important approach to an arterial road), whereas an unsignalized urban intersection may have a small island (Austroads 2017. *Guide to Road Design Part 4 A Unsignalised and Signalised Intersections*).
- Island noses should be offset from the edge of the adjacent traffic lane to provide additional clearance to the curb to enhance comfort for approaching drivers and prevent any tendency for them to shy away from the curb.
- As a general guide, the island nose should be offset by 0.2 m per 10 km/h of approach speed, but this is not used by all jurisdictions. On narrow islands where an offset to the approach nose is not practicable, a fully mountable nose may be provided, which requires a smaller offset and nose radius than a curb. However, where this cannot be achieved because of limited visibility to intersections that are located on crests or relatively tight curves, raised median islands in the major road can be used to improve driver perception of the intersection. In such cases the island nose should be designed to a length that carries it over the crest or around the curve to a point where it can be easily seen (see section on Median).
- Curbed islands are sometimes difficult to see at night because of the glare from oncoming

154 Austroads. 2012. Effectiveness of road safety engineering treatments, AP-R422-12.

headlights or from distant luminaires or roadside businesses. Curbed islands generally should not be used in rural areas and at isolated locations unless the intersection is lighted and curbs are delineated, such as with curb-top reflectors.

- Channelization at lower cost is the placement of painted islands/medians to narrow the lanes and reduce approach speeds. This is supplemented by rumble strips within this median and along the outside of the edge lines of the pavement (see section 3.2 on Speed compliance and traffic calming).
- An auxiliary lane should be of sufficient width (including that of shoulders adjacent to auxiliary lanes) and length to enable a driver to maneuver a vehicle into it properly, and once in it, to reduce speed for turning at the intersection.
- The storage length should be sufficient to avoid turning vehicles stopping in the through lanes waiting for a signal change or for a gap in the opposing traffic flow. A longer lane should be considered in situations where there is a high volume of trucks turning, a grade, or a high design speed. The inability of turning vehicles to access turn lanes can adversely affect the capacity of an intersection and result in vehicles encroaching onto medians and causing maintenance issues.
- However, the taper length should not be too long to ensure that the commencement of the auxiliary lane is well-defined, and drivers do not inadvertently enter the lane during inclement weather or on a horizontal curve.
- The design should allow for an occasional large truck to turn by swinging wide and encroaching on other traffic lanes without disrupting traffic significantly.
- Where curbing is to be used adjacent to the auxiliary lane, an appropriate curb offset should be provided to be able to accommodate vehicles.
- Parking should be restricted for a distance in advance of the right, nearside turning radius to avoid encroachment on adjacent spaces of the turning lanes.
- For arterial street design, adequate radii for vehicle operation should be balanced against the needs of pedestrians and the difficulty of acquiring additional right-of-way or corner setbacks. Because the corner radius is often a compromise, its effect on both pedestrians and vehicular movements should be examined.

Figures 6.61 through 6.65 show some good and bad examples of delineation for turning movements.

For vulnerable road user safety:

- Install a raised island of adequate size to provide refuge where pedestrian crossings are expected (figure 6.66). Islands used for channelization should not interfere with or obstruct cycle lanes at intersections.
- Drivers should not be suddenly confronted with an unusable area in the normal vehicle path. Islands first approached by traffic should be indicated by a gradually widening and marking or a rumble strip on each side.
- Place the crosswalk in the center of the turning roadway (further away from the intersection corner) perpendicular to the direction of travel (without making it an inconvenient detour for pedestrians), and use landscaping, etc., to prevent pedestrians from crossing elsewhere (figures 6.67 and 6.68). In addition, the crosswalk and curb ramp should be kept a distance equivalent to one or two car lengths (i.e., usually 6 m or 12 m) back from the holding line so that the crossing is coincident with a space between queued cars, which will allow drivers on the approach leg to look for and yield to pedestrians before reaching the intersecting roadway and scanning for gaps in traffic.
- Adequate stopping sight distance should be provided to pedestrians, particularly to crossings of slip lanes where speeds are higher than locations with smaller corner radii. Other situations where special consideration of cyclists and treatments is required to assist access and safety include on approaches where the skew of an intersection necessitates provision of a slip lane on the corner of a roundabout



**Figure 6.61:** No marking slip lane in Tanzania.



Source: World Bank.

**Figure 6.62:** Poor delineated slip lane in Ghana.



Source: Graphic Online. <https://www.graphic.com.gh/news/general-news/accra-chokes-heavy-traffic-slows-business-field-day-for-okada-operators.html>.

**Figure 6.63:** Slip lane with zigzag pavement marking in Singapore.



Source: Google street view.

**Figure 6.64:** Large urban intersection with pavement marking delineation for turning movements.



Source: © Google Earth.

**Figure 6.65:** Minor road treatment with flexible poles.

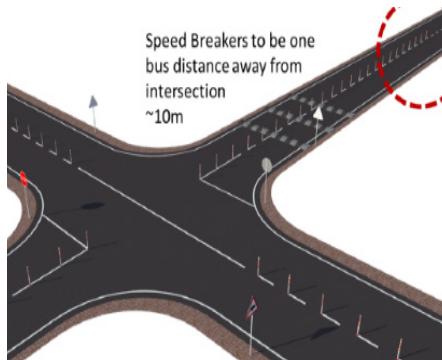

Source: Indian Institute of Technology, Kharagpur. 2019. Report on Road Safety Audit of SH-11 During Operation Stage, India.

**Figure 6.66:** Pedestrian refuge and cyclist way finding.



Source: FHWA

**Figure 6.67:** Wide-angled slip lane with poorly aligned crossings and lack of crossing.



Source: Un-Habitat. .

**Figure 6.68:** A well-designed right turn slip lane at a complex intersection.



Source: Designing for Pedestrian Safety.



(e.g., marked cycle lanes). The driver may not see (cognitive and physical) cyclists crossing the road the driver wants to turn into (potentially due to driver distraction, or cyclists speed misjudged).

- Whenever feasible, signal and other utility poles and signs should be placed outside of paved pedestrian walkways and landing areas. Care should be taken to avoid placing these objects in conflict with future pedestrian facilities.
- Providing a buffer space whenever sidewalks are constructed adds separation between pedestrians and the travelled way.
- Appropriate cycle treatments, including line marking and signs for drivers using the slip lane to watch for cyclists, may be required adjacent to the island forming slip lanes.
- Priority at crossings should be clear for all road users (i.e., whether motorists, pedestrians, or cyclists have priority).
- At intersections with channelization, lighting systems should be installed for illuminating islands, diverge and merge locations, turning roadways, and pedestrian crossings.
- A refuge island for pedestrians at or near a crosswalk or cycle path that aids and protects pedestrians and cyclists who cross the roadway should be provided with slip and turn lanes.
- Raised curb corner islands and center channelizing or divisional islands can be used as refuge areas. Refuge islands (for pedestrians and cyclists crossing a wide street, for loading or unloading transit

**Figure 6.69:** Raised crosswalk on slip lane with ghost island markings and crosswalk signs.



Source: The State of Queensland. .

riders, or for wheelchair ramps) are used primarily in urban areas.

- Where pedestrians and cyclists are expected to cross a slip or turn lane, low vehicle speeds should be encouraged at the crossing point.
- Using physical devices (e.g., road hump or special marked [such as a wombat]) crossing on slip and turn lanes can reduce vehicle speeds and improve visibility of crosswalks (figure 6.69).
- During recent years in some countries such as the US and Australia, inappropriately designed slip lanes have been converted to a space for pedestrians or cyclists, because these slip lanes can be harmful for safety (figures 6.70 through 6.72). For example, a short slip lane (no safety devices for pedestrian on crosswalks) that carves up the sidewalk only so drivers can take turns faster is dangerous. Many cities converted to pedestrian plazas.

**Figure 6.70:** Transformation to mini plaza in USA.

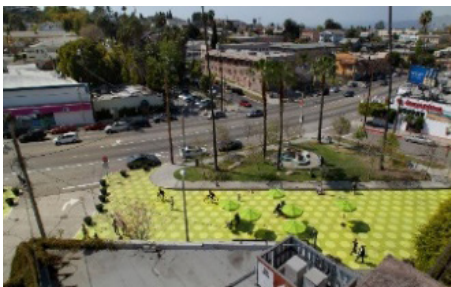

Source: LADOT people St (CC BY-ND 2.0).

**Figure 6.71:** Transformation to street cycle lane in the US.



Source: Google streetview.

**Figure 6.72:** Transformation to footpaths in the US.

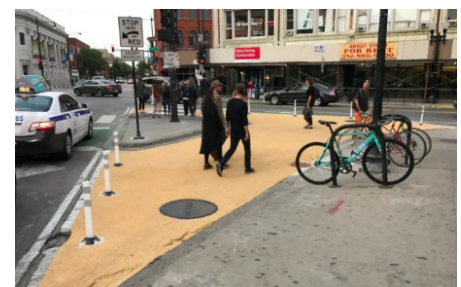

Source: John Greenfield/Streetsblogusa.

## Further Reading

- AASHTO. 2018. Green Book (GDHS-7). Must read chapter 2, Design controls and criteria; chapter 5, Local roads and streets; chapter 6, Collectors in urban areas; chapter 7, Arterial road.
- FHWA. 2014. A Report on the Development of Guidelines for Applying Right-Turn Slip Lanes. Must read chapter 2, Literature review.
- Austroads. 2017. Guide to Road Design. Must read Part 4A, Unsignalised and Signalised Intersections.
- Austroads. 2015. Road Geometry Study for Improved Rural Safety. Must read chapter 6, Design elements for improved rural road safety.
- Rune Elvik. 2009. The Handbook of Road Safety Measures, Second edition. Must read Part II, Road Safety Measure.

## 6.6. Left-in Left-out/Right-in Right-out

### General description

Left-in/left-out (LILO) and right-in/right-out (RIRO) refer to a type of three-way road intersection where turning movements of vehicles are restricted. RIRO is

typical when vehicles drive on the right, and LILO is typical where vehicles drive on the left. This is because minor roads usually connect to the outsides of two-way roads.

A LILO permits only left turns and a RIRO permits only right turns. “Right-in” and “left-in” refer to turns from a main road into an intersection (or a driveway or parcel); “right-out” and “left-out” refer to turns from an intersection (or a driveway or parcel) to a main road. They are implemented to prevent the turning maneuver across opposing lanes of traffic.

### Safety implication

- RIRO/LILO configurations generally improve road traffic safety and efficiency by reducing the number of conflict points between vehicles (figure 6.73). In particular, they eliminate the high severity risks of turning traffic versus through traffic. Turning movement restrictions are a type of access management strategy used to improve the safety of stop-controlled intersections and driveways. Restricted and prohibited turn movements reduce the number of turning conflict points at intersections, which are generally known to reduce crash risk.<sup>155</sup>
- According to the literature, 74 percent of driveway crashes involve offside turn maneuvers where

**Figure 6.73:** Sketch of change in conflict points with RIRO arrangement.

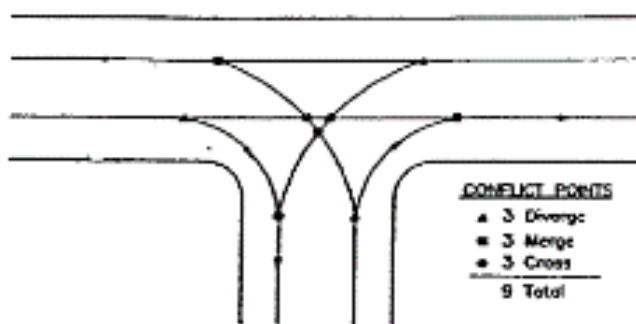

Source: Oregon Department of Transportation, 1998.

Three-way intersection before restriction

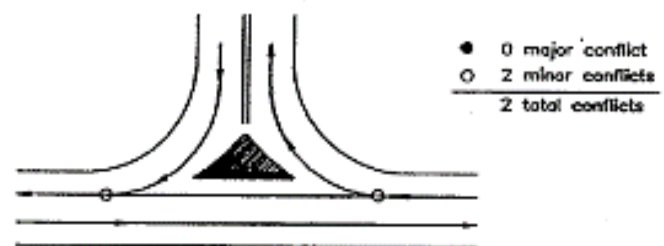

RIRO intersection

155 Simodynes, T., Welch, T., and Kuntemeyer, M. 2000. Effects of Reducing Conflict Points on Reducing Accidents (abstract), Third National Access Management Conference, p. 141, Federal Highway Administration, Washington, DC.

**Figure 6.74:** RIRO junction with too close offset right turn in Ukraine.



Source: © Google Earth.

**Figure 6.75:** Urban LILO Brunei with insufficient space for safe lane change to offside right turn.



Source: © John Barrell.

emerging vehicles have to cross opposing traffic lanes.<sup>156</sup>

- RIRO/LILO are only effective where this turning maneuver is effectively prevented, usually by a physical barrier or raised island. Legal restrictions on turning maneuvers (those without physical restrictions) are much less effective and open to abuse. Therefore, they are most common where

there is a divided carriageway and no median crossing.

- There is some evidence that RIRO without physically preventing left turn movements can result in higher crash rates than those with a physical prohibition.<sup>157</sup>
- A RIRO/LILO configuration may improve safety and operations at one intersection while consequently worsening them at another intersection upstream or downstream.
- Crash migration is a potential issue related to restricted turning movements at a given access point. This occurs when crashes at a treated site shift to another site. While RIRO/LILO operations eliminate turns across opposing flows at the subject location, U-turn movements and related crashes potentially increase at the next intersection downstream that allows U-turns.
- They also introduce additional collision patterns as vehicles attempt to cross the main running lanes and merge with traffic in opposing directions (figures 6.74 and 6.75). As such, at a full movement

156 National Highway Institute. 1992. Access Management, Location and Design: Participant Notebook, NHI Course No. 15255, U.S. Department of Transportation, Federal Highway Administration, Washington, DC.

157 Sarath Chandra Gorthy. 2017. Analysis of Right-in, Right-out Commercial Driveway Safety, Operations and Use of Channelization as Compliance Countermeasure. MSc Thesis, Clemson University.



signalized intersection within a corridor, there could be an increase in U-turn movements from both directions along the main line if the stop-controlled intersections are converted to RIRO along the corridor.

- RIRO junction with offset right turn too close and insufficient weaving length between movements (also incorporates pedestrian crossing and public transport stop). Turning and storage needs to accommodate all vehicles, including heavy goods vehicles (HGVs).

### Good design practice/ treatments/solutions

- RIRO/LILO intersections should be designed with a physical median in the mouth of the junction that is effective in preventing an unauthorized turn.
- Single lane approaches are most effective in preventing this unauthorized turn.
- Where the main highway is a single carriageway, a physical barrier is also needed on the main highway.
- Where the main highway is a dual carriageway, the intersection should be designed as though the deceleration lane were an off-ramp and the acceleration lane an on-ramp, with physical separation between the decelerating/accelerating traffic emphasizing the intersection and converting the turn movement into a merge. This philosophy is similar to the examples shown in the next section.
- The ability to undertake the prohibited maneuver at the RIRO/LILO intersections needs to be possible at the next available intersections. As these are effective U-turns into the offside of the opposing traffic stream, they must be made under controlled conditions with higher quality turning facilities—either a signal control or at a roundabout (figure 6.76).
- The use of an offset median crossing merely transfers the merge problem to another location.

**Figure 6.76:** Illustration of replaced turning movement at downstream junction.

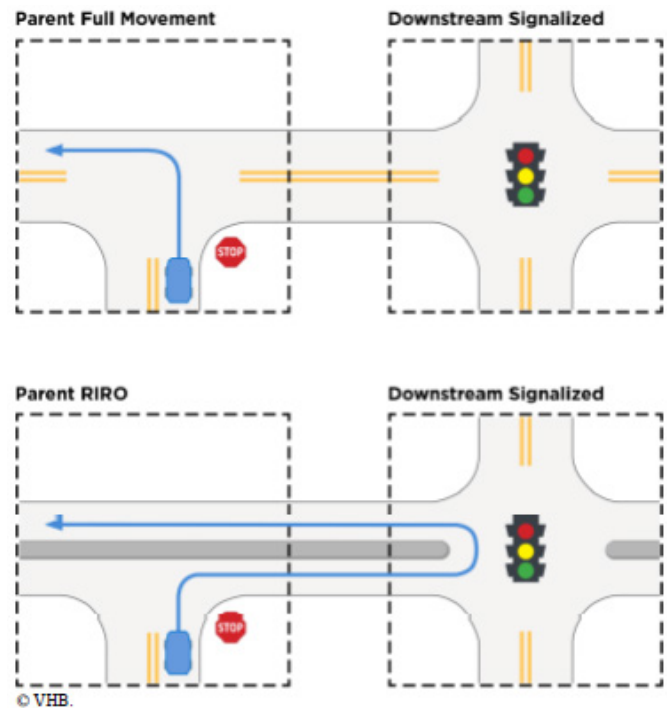

Source: FHWA, 2012.

- Wherever this turn is allowed, it should be at a sufficient distance from the RIRO/LILO to allow emerging traffic to safely cross the main traffic lanes and allow approaching vehicles to anticipate vehicles slowing for the offside turn.

### Further Reading

Ahmet Aksan, Robert Layton. 1998. Right-In Right-Out Channelization Discussion Paper No. 13 prepared for Oregon Department of Transportation presented at the 3rd National Conference on Access Management Transportation Research Board Fort Lauderdale, Florida, October 4–7, 1998.

FHWA. 2012. Safety Evaluation of Turning Movement Restrictions at Stop-Controlled Intersections. FHWA Publication No. FHWA-HRT-17-065.

Mn/DOT Access Management Manual. 2008. Must read chapter 3, Guidelines and Public Street and Driveway Connections.

## 6.7. Acceleration and Deceleration Lanes

### General description

Acceleration/deceleration lanes (also known as speed change lanes) provide drivers with an opportunity to speed up or slow down in a space not used by high-speed through traffic (figure 6.77).

Merging can occur at on-ramps to freeways or multilane highways, or when two significant facilities join to form a single traffic stream.

Merging vehicles often make lane changes to align themselves in lanes appropriate to their desired movement.

Diverging occurs when one traffic stream separates to form two separate traffic streams. This occurs at off-ramps from freeways and multilane highways, but can also occur when a major facility splits to form two separate facilities. Again, diverging vehicles must properly align themselves in appropriate lanes, thus indicating lane changing; non-diverging vehicles also make lane changes to avoid the turbulence created by diverge maneuvers.

**Figure 6.77:** Illustration of acceleration and deceleration lanes.

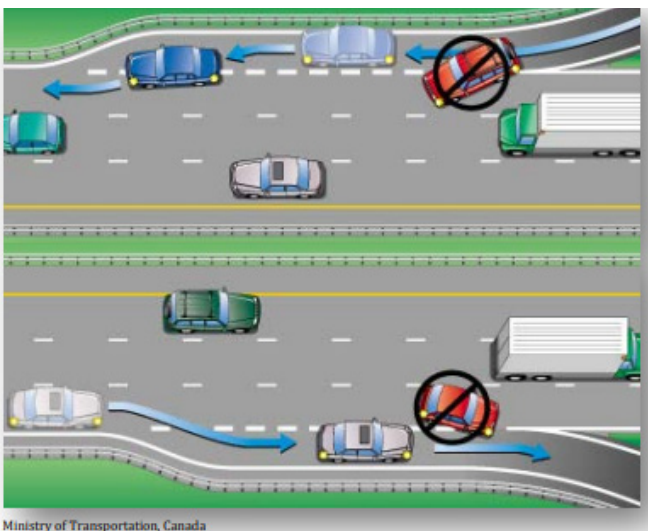

**Figure 6.78:** Deceleration lane approach tight exit radius—Brunei.



Source: © John Barrell.

**Figure 6.79:** Well defined acceleration lane—Brunei.



Source: © John Barrell.

On freeways and some major streets, the speed change between the main lanes and the adjacent streets can be substantial and cause stop- and-go traffic and more collisions for the main vehicle flow.

While these speed change lanes are most often associated with high-speed roads, they can be included as part of lower speed RIRO/LILO junctions where capacity requires side road traffic to enter high-volume roads.

Dedicated acceleration lanes allow vehicles that have turned onto the main road to speed up to match the flow of traffic. Deceleration lanes allow vehicles leaving the high-speed main road to slow down to match the side road traffic or negotiate a tighter road alignment at exit.

**Figure 6.80:** Offside diverge lane—Brunei—narrow median and lane requiring additional space beyond turn.



Source: © John Barrell.

## Safety implications

- Acceleration and deceleration lanes may be blocked by parked or stopped vehicles.
- Drivers using acceleration lanes have a narrow angle of vision with the main road flow.
- Drivers merging in a stream of vehicles may have difficulty in watching both the vehicles on the main stream and those that are merging.
- Those wishing to leave the multilane highway into a speed change lane need ample warning to move safely into the nearside lane in sufficient time to enter at the start of the lane.
- Congestion, if the number of vehicles goes beyond the capacity, can increase collisions as vehicles slow or stop unexpectedly.
- If lanes do not have sufficient capacity for all vehicles, then queues can back onto the main carriageway causing additional rear-end collisions.
- Where speed change lanes are included on multi-lane highways, the lane changing of vehicles within the main streams can reduce free flow capacity.
- Late entry and early exit from a speed change lane can increase the risk of collisions.

**Figure 6.81:** Additional barrier to offside diverge—Brunei—to control entry and turning area beyond far carriageway for ALL vehicles, adding additional merge after crossing opposing traffic.



Source: © John Barrell.

- The spacing between merge and diverge speed change lanes can result in disruption to main line flow and result in excessive sideswipe and rear-end collisions.

## Good design practice/ treatments/solutions

- Good visibility should be maintained for both emerging and approaching traffic.
- Clear signing and marking of lanes are crucial to safety.
- Visibility in the night can be enhanced by using reflective road studs of different colors.
- In the case of a perpendicular approach to merging lanes, the line of sight should be kept free from street furniture, barriers, and road signs.
- To avoid obstruction on the lanes, parking restrictions should be implemented and strictly followed.
- Speed change lanes should be kept free in case of congestion. Therefore, the capacity of the main road and volume of merging traffic need to be calculated to allow free flow conditions under all circumstances. When queues develop, the effective length of the lane is reduced.



- Similarly, the upstream capacity of the main road is a major consideration when large amounts of traffic need to use the deceleration lane off a multilane highway and relative speeds and lane changing will be an issue.
- Length of the lanes should be long enough to accommodate all the traffic if traffic volume is very high on the main stream. Where intersections with speed change lanes are close together, sufficient weaving length is needed to maintain stable flow conditions between intersections.
- Markos Alito Atamo. 2012. Safety Assessment of Freeway Merging and Diverging Influence Areas Based on Conflict Analysis of Simulated Traffic. PhD Thesis, University of Colorado. Chapter 2, Literature review.

## 6.8. Grade Separation and Ramps

### General description

Most crashes happen at intersections. The best way of stopping conflicting intersection movements is placing the intersecting roads at different levels, or grade separating them. This can be done with overpasses or interchanges.

An overpass is a simple grade separation of two roads whereby there is no actual link between them and hence no exchange of traffic is possible (figure 6.82). Overpasses are typically used when a minor road crosses a major road, and where a rail line crosses a road.

Interchanges are grade-separated intersections where

### Further reading

- G. T. Wall, and N. B. Hounsell. 2004. A Critical Review of the Standards and Design Processes for Motorway. Must read chapter 2, Evolution of standards for motorway diverges; chapter 3, Introduction to the diverging flow-region diagram; chapter 6, Critical review of the diverging flow-region diagram.
- Diverges in the UK School of Civil Engineering and the Environment University of Southampton Southampton, UK.

**Figure 6.82:** A simple overpass with no connection between the two routes—Ethiopia.



Source: © John Barrell.

traffic from one main road is connected to another main road via free flow connecting roads.

An interchange allows traffic to move between two or more roads that are grade separated. Interchanges vary from simple arrangements with ramps and intersections at the minor road to complex layouts where two or more freeways (major highways or motorways) connect.

Overpasses and interchanges are very costly and are usually built as part of a freeway system where large traffic flows justify the cost. Occasionally, interchanges and overpasses are built on busy urban highways when justified by road safety and traffic flow improvements.

In full grade-separated interchanges, with separate lanes for all streams of traffic, all movements that

require crossing other streams of traffic are removed and reduced to changing traffic lanes.

Various forms of interchanges have been developed, such as diamond interchanges, trumpet interchanges, and full or partial cloverleaf interchanges (figure 6.83). These interchanges differ with respect to the types of ramps that are built for turning traffic.

Partial grade-separated intersections (figure 6.84) are those where there is no at-grade connection between two main roads, but where the connections between ramps and main roads are at grade (instead of acceleration/deceleration lanes).

Ramps joining one of the intersecting roads may be in the form of an at-grade intersection such as priority intersection, signalized intersection, or roundabout.

**Figure 6.83:** Typical full grade-separated interchange layouts.

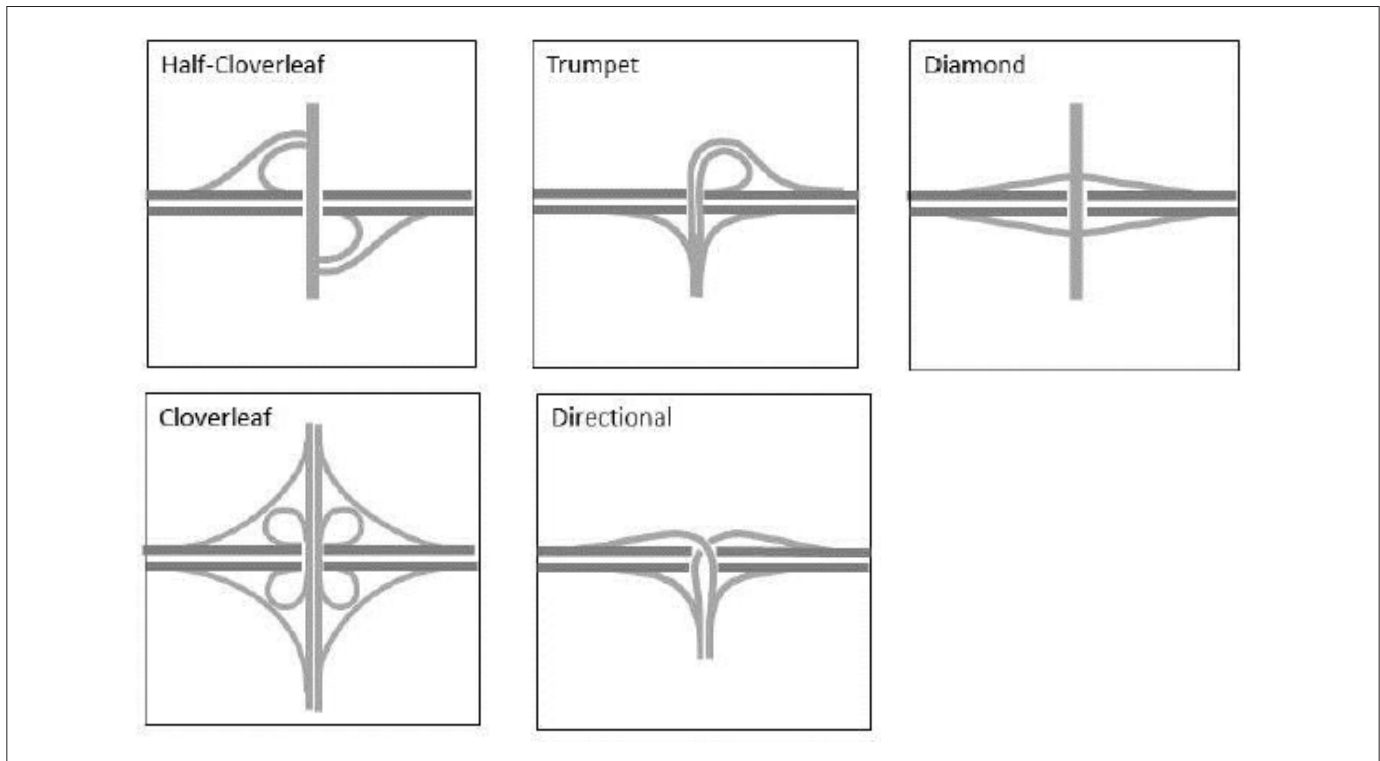

Source: © John Barrell.

Figure 6.84: Typical partial grade-separated interchanges layouts.

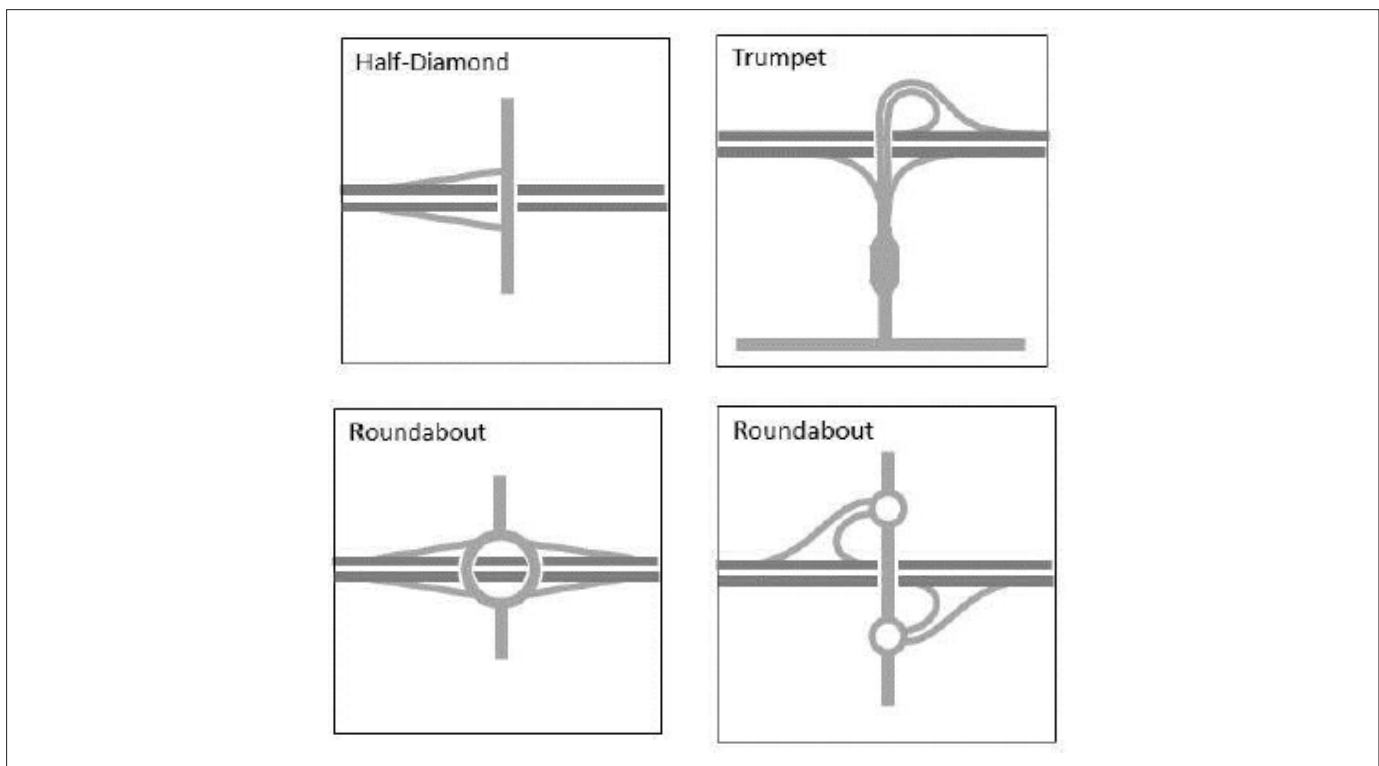

Source: © John Barrell.

## Safety implications

- According to research,<sup>158</sup> the crash rate is lower at grade-separated junctions than at at-grade junctions. The largest differences have been found in four-way intersections. At these, the reduction of the number of injury crashes is larger than the reduction of the number of property-damage-only crashes.
- The crashes around grade-separated intersections include crashes on ramps, but not crashes on comparable stretches of road immediately before and after at-grade junctions. If these crashes were included in the calculation of the effects on crashes, still larger reductions of the number of crashes on grade-separated junctions would probably have been found. However, ramps are a new road element when grade-separated junctions are constructed, and their effects on safety should be included in the effects of grade-separated junctions.
- Partly grade-separated junctions have been found to be less safe than grade-separated junctions, but safer than at-grade four-way intersections. When at-grade four-way intersections are equipped with speed cameras, these are safer than partly grade-separated junctions without speed cameras. No significant difference has been found between partly grade-separated and signalized junctions.
- Diamond interchanges (simple and comprehensive, with straight ramps, and with minor roads running above the main road) appear to be the safest form of grade-separated interchanges.
- Diamond interchanges have lower crash rates than

158 Elvik, R., Høy, A., Vaa, T., and Sørensen, M. 2009. The Handbook of Road Safety Measures, 2nd ed., Emerald Group, United Kingdom.



most other types of interchanges. Most differences are only small and not significant. Diamond interchanges are most favorable in comparison with trumpet interchanges and junctions with direct access ramps. There are several factors that make diamond interchanges relatively safe: the layout is relatively simple and thereby reduces confusion or errors among drivers. Ramps in diamond interchanges are straight, and crash rates are smaller on straight ramps than on curved ramps or loops.

- The studies have found that there are more crashes in curves with a smaller radius than in curves with a larger radius.<sup>159</sup>
- It is possible that the higher speeds on motorways on the approach to loops may be a contributory factor to crashes, particularly on diverge loops.
- HGVs are particularly susceptible to rollover incidents on curved ramps or loops due to the tight radius and potential for high speed.
- Short or frequent spacing between intersections can result in short weaving lengths between associated merge/diverge/speed change lanes.

## Good design practice/ treatments/solutions

- Several features and issues are common to all types of interchanges. These items are important to consider in all contexts.
- Common elements include:
  1. Clear sight lines (vertical and horizontal),
  2. Interchange form—appropriate for traffic types and patterns,
  3. Appropriate horizontal/vertical geometry,
  4. Adequate speed change lanes,
  5. Driver expectancy/positive guidance—adequate perception/reaction distances for typical

maneuvers and all exits/entrances to the right of through traffic,

6. Design vehicle offtracking,
  7. Adequate storage for vehicle queues, and
  8. Adequate accommodation for signing.
- Interchanges should be located such that merging and diverging areas are sited on straight or near straight alignment with gentle gradients.
  - Where feasible, it is preferable to provide exit slip roads on uphill gradients to facilitate deceleration, and conversely, entry slip roads on downhill gradients to facilitate acceleration. As such, it is generally not advisable to locate grade-separated intersections at a hilltop due to unfavorable gradients. Drivers are also more likely to be affected by bright sun glare on the approach.
  - Grade-separated intersections should be relatively simple, with a minimum number of decision points which are spaced well apart. They should enable all drivers to readily identify the direction with minimal need for lane changing. Where more complex road connections are unavoidable, notably within cities and at their peripheries, every effort should be made to simplify the layout and provide adequate and well-designed directional signing.
  - Ramps generally have lower design speeds than the main line, but the difference should not be excessive. It is important that changes to a lower design speed are predictable and obvious to drivers, and there is adequate distance for deceleration.
  - Loops are ramps which turn through more than 120 degrees on a small radius curve. They are typical of grade-separated intersections in the trumpet or cloverleaf layout. Loops should not consist of more than one lane per direction.
  - Measures to maintain safety are necessary, and measures to consider include:
    1. Provision and maintenance of clear visibility

<sup>159</sup> Rune Elvik, *Handbook of Road Safety Measures*, p. 236.

over the whole of the loop on the approaches, especially beyond an underbridge or other structure,

2. Advisory speed limits and/or bend signs and “chevron” warning signs,
  3. Widening of lanes on the loops as appropriate for lower radii,
  4. The provision of vehicle restraint systems on the outside of curves,
  5. Physical separation of opposing traffic streams,
  6. Lighting, and
  7. High skid resistant surfacing.
- Cyclist and pedestrian movements must be accommodated through interchanges, even in rural locations. In urban or suburban areas where sidewalks are in place, the existing accommodations may not be suitable for current needs. It is equally important to develop the design for bikes and pedestrians, as well as vehicles. Some interchange configurations (such as the single point or diverging diamond) require multistage crossings and refuge islands. Occasionally it is necessary to provide separated facilities through complex interchanges.
  - Grade-separated interchanges are complex highway elements, and every discipline involved in the design (geometry, traffic, structure) needs to coordinate to ensure the needs of various users are met.

## Further Reading

- Oregon Department of Transport Highway Design Manual. 2012. Must read chapter 9.
- Transport Infrastructure Ireland (TII) Layout of Graded Separated Junctions DN-GEO-0303 2009. Must read chapter 4, Geometric standards and chapter 5, Layout options.

## 6.9. Rail Crossings

### General description

Rail networks are defined corridors where vehicles move on defined and immovable rails. They are commonly situated in dedicated corridors with only limited and controlled interaction with other forms of land transport (cars, vans, motorcycles, cycles, and pedestrians) on the highway network.

In previous centuries rail transportation was also common on the streets of major cities in the form of trams or streetcars. In many cities that had abandoned these systems, they are now being reintroduced, either on streets or in separate dedicated corridors.

They all share the requirement—to varying degrees—to positively cross the running carriageway of general traffic. These, whether for conventional heavy rail or urban tramway/light rail systems, all include rail crossings to varying degrees.

All these interactions must be undertaken under controlled conditions.

Rail crossings are intersections where a highway crosses a rail track at grade and are the physical intersection of two very different vehicle-carrying surfaces and areas approaching the physical intersection. Within the crossing area, physical design characteristics of each structure, i.e., rail and highway, may have to be specifically adjusted to accommodate the other transportation mode smoothly and safely.

Some international rules have helped to harmonize level crossings, for instance, the 1968 Vienna Convention which requires standard warning signs and lines, and potential barriers. This has been implemented in many countries, including countries which are not part of the Vienna Convention.

Early crossings had a flagman in a nearby booth who would, on the approach of a train, wave a red flag or lantern to stop all traffic and clear the tracks.

Gated crossings became commonplace in many areas, as they protected the railway from people and livestock trespassing, and they protected the users of the crossing when closed by the signalman/gateman.

In the second quarter of the twentieth century, manual or electrical closable gates that barricaded the roadway started to be introduced, intended to be a complete barrier against intrusion of any road traffic onto the railway.

Automatic crossings are now commonplace, although each of the systems described above are still used in some LMICs. Full, one-half, or no barrier crossings superseded gated crossings, although crossings of older types can still be found in places.

In rural regions with sparse traffic, the least expensive type of level crossing to operate is one without flagmen or gates, with only a warning sign posted. This type has been common across North America and in many developing countries.

## Safety implications

- Level crossings constitute a significant safety concern internationally. On average, each year around 400 people in the European Union and over 300 in the United States are killed in level crossing crashes.
- Collisions can occur with vehicles as well as pedestrians; pedestrian collisions are more likely to result in a fatality.<sup>160</sup> Among pedestrians, young people (5–19 years), older people (60 years and over), and males are considered to be at high risk<sup>161</sup> due to their attitude to risk or lack of general awareness.
- Rail crossings can be dangerous if:
  1. There is poor sight distance to a signal display, or to approaching trains,
  2. Traffic control is inadequate,
  3. Vehicles queue across tracks due to congestion or nearby intersections,
  4. There is a lack of pedestrian facilities,
  5. Either road or rail pavement is not maintained,
  6. Signaling equipment is located too close to the road that can result in unnecessary damage by passing vehicles, and
  7. Vertical profile of road over rail crossing results in grounding of road vehicles.
- Signalized intersections at or near grade crossings possess added concerns over intersections that are stop controlled. If traffic signals are not properly coordinated with railroad operations, severe crashes can occur.
- When a highway-railroad grade crossing is located near a signalized intersection, it is possible that queues from the intersection could extend over the grade crossing and potentially cause stopped vehicles to become trapped on the tracks.
- Similar situations can occur at uncontrolled intersections close to rail crossings where long vehicles can block the crossing.
- When a long-wheelbase or low-ground-clearance vehicle negotiates a roadway having a high vertical profile, such as a highway-railroad grade crossing, roadway crown, or driveway entrance, the vehicle may become lodged or stuck on the “hump.” A somewhat common occurrence is one in which a railroad is on an embankment and a low-ground-clearance vehicle on the crossing roadway becomes lodged on the track and is subsequently struck by a train.

160 Australian Transport Safety Bureau. 2004. “Level crossing accident fatalities.”

161 Lloyd’s Register Rail. 2007. “Study of pedestrian behaviour at public railway crossings.” Public Transport Safety Victoria.



## Good design practice/ treatments/solutions

- Trains have a much larger mass relative to their braking capability, and thus a far longer braking distance than road vehicles. With rare exceptions, trains do not stop at level crossings and rely on vehicles and pedestrians to clear the tracks in advance.
- Level crossings (figures 6.85 through 6.88) are controlled through either passive or active systems. Passive control systems provide warnings through signs and line markings. They do not react to the

presence of an approaching train. Active traffic control systems warn road users of approaching trains.

- Adequacy of sight distance is critical at passive crossings; however, even where active devices are present or will be provided, sight distance is beneficial to confirm the ability to cross the tracks.
- The US Traffic Control Devices Handbook (2nd edition)<sup>162</sup> indicates three zones within the approach to a crossing where drivers make decisions about their movements in relation to the crossing. It identifies three zones of visibility as well as the respective sight distance associated with each, and MTCO refers to the “minimum track clearance distance”

**Figure 6.85:** Rail crossing UK.



Source: Archant. Hunt Post. <https://www.huntspost.co.uk/news/final-plan-for-offord-cluny-s-new-rail-crossing-to-5013974>.

**Figure 6.87:** Rural rail crossing—Zimbabwe (passive).



Source: © John Barrell.

**Figure 6.86:** Automatic signal controlled crossing—Dubai tram.



Source: © John Barrell.

**Figure 6.88:** Rural rail crossing—Australia (active).



Source: Department of Transport and Main Roads, Queensland Government.

162 Seyfried, R. K., and P. E., PTOE. 2013. Traffic Control Devices Handbook (2nd edition). Washington, DC: ITE.

**Figure 6.89:** Visibility zones approaching a passively controlled rail crossing.

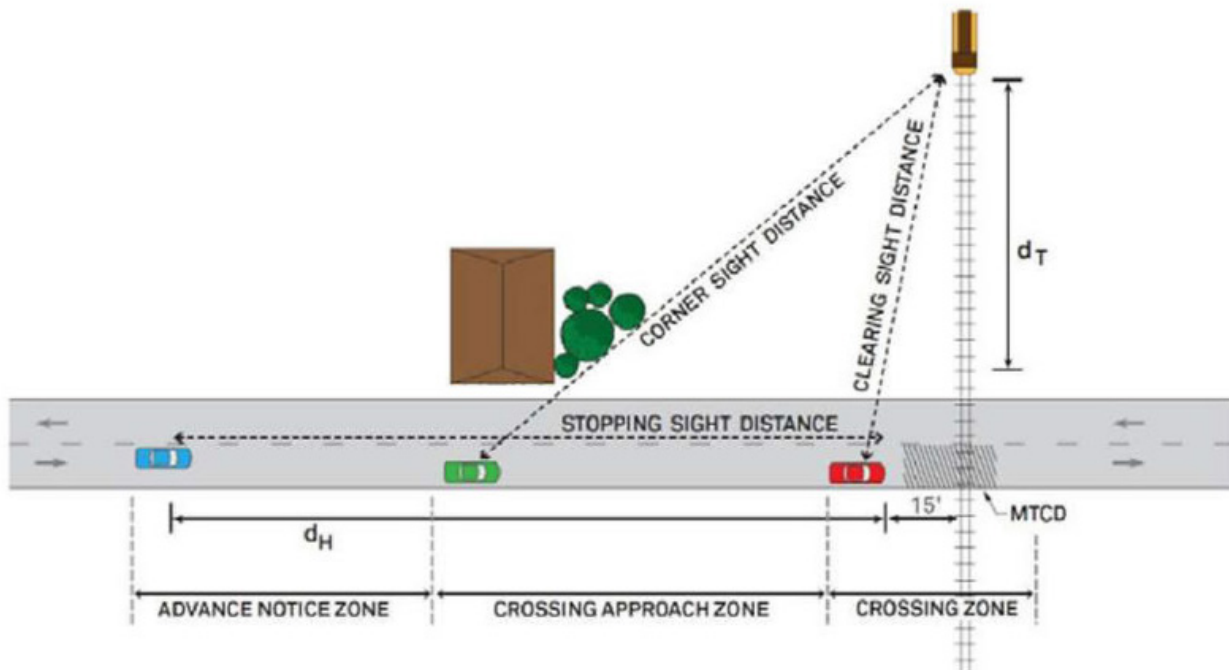

Source: FHWA, 2019. Ogden, B. D., and Cooper, C. 2019. Highway-rail crossing handbook (No. FHWA-SA-18-040). United States. Federal Highway Administration.

at the crossing, which should be clear of vehicles when a train is approaching. It also indicates for each zone the desired roadway user response, depending upon whether a train is visible or not (figure 6.89).

- Warnings at active controlled crossings consist of flashing lights and sounds (combined with static controls such as signs and pavement markings) which are triggered by a train.
- As with passive crossings, adequate visibility of these devices is necessary for approaching road users.
- Another level of active control is achieved by placing a barrier between vehicles or pedestrians and trains. This is done with electro-mechanical devices such as pedestrian gates and vehicle boom barriers used in combination with other active and passive controls.
- Intersections near highway-railroad grade crossings require special attention to coordinate the movements of vehicle, train, and pedestrian traffic.
- To avoid queues from an intersection blocking a

crossing, traffic signals located near highway-railroad grade crossings need to be synchronized when trains approach in order to clear vehicles off the tracks before the train arrives. This synchronization is normally achieved through an electrical interconnection circuit between the railroad grade crossing warning system and the highway traffic signal controller assembly. The geometric design of any signalized intersection near a highway-railroad grade crossing should consider interconnection and synchronization.

- Sufficient space is needed to ensure that waiting vehicles can wait safely to clear a crossing.
- Approach to rail crossings therefore needs to be as flat or straight as possible to allow clearance for long wheelbase vehicles.
- Opportunities should be considered to close low-volume crossings where a viable alternative exists.
- Several assessment tools exist for the determination of risk at rail crossings (e.g., ALCRM in the UK and ALCAM in Australia and New Zealand).

## Further Reading

- Texas Department of Transportation. 2000. Design Guidelines for At-Grade Intersections Near Highway-Railroad Grade Crossings. Must read chapter 3, Interconnection.
- Manual of Uniform Traffic Control Devices for Streets and Highways (MUTCD) 2nd edition. 2009, with 2012 updates. US Department of Transport Federal Highways Administration. Must read part 8, Traffic Control for Railroad and Light Rail Transit Grade Crossings.